

ATP 300
PRO

ATP 600
PRO

User manual



Contents

1	Introduction	3
1.1	Product features	5
1.1.1	Standard features	5
1.1.2	Optional features	6
1.2	General specifications	6
1.3	Print specifications.....	7
1.4	Ribbon specifications	7
1.5	Media specifications.....	7
2	Product overview	8
2.1	Unpacking the printer	8
2.2	Printer overview.....	9
2.2.1	Front view	9
2.2.2	Interior view	10
2.2.3	Rear view	11
3	Setup.....	12
3.1	Printer setup.....	12
3.2	Installing the ink ribbon	13
3.3	Loading media	17
3.3.1	Placing media in the printer	17
3.3.2	Sensor setup	20
4	LCD display menu	21
4.1	LCD display.....	21
4.2	Main menu.....	21
4.3	Calibration	22
4.3.1	Auto calibration.....	22
4.3.2	Manual Setup	23
4.3.3	Threshold detect.....	26
4.3.4	Maximum length	26
4.3.5	Advanced.....	26
4.3.6	Minimum paper length (advanced).....	27
4.3.7	Maximum paper length (advanced).....	27
4.4	Settings	27
4.4.1	1st label adjustment	27

4.4.2	Interface	28
4.4.3	Diagnostics.....	30
4.4.4	Advanced.....	32
4.4.5	Factory default	35
4.5	File manager.....	35
4.6	Info.....	36
4.6.1	Instruction videos	36
4.6.2	Printer info.....	37
4.6.3	Contact details.....	37
4.7	Errors and messages	38
5	Printer Web Interface.....	39
5.1	Accessing the Printer Web Interface.....	39
5.2	Configuration.....	40
5.3	Tools	43
6	Printer management tool (TPM).....	45
6.1	TPM overview.....	45
6.2	Printer settings.....	46
6.2.1	Printer configuration.....	46
6.2.2	File manager.....	50
6.2.3	Command tool	50
6.2.4	RTC Setup.....	51
6.2.5	Printer function	51
6.2.6	Bitmap Font Manager.....	52
6.3	Program settings.....	53
6.3.1	Users.....	53
6.3.2	Alert	53
6.3.3	Group.....	54
6.3.4	Setup.....	54
6.3.5	Manual name	54
7	Cleaning	55
7.1	Cleaning the printer	55
8	Support (FAQ).....	57

1 Introduction

Industrial Desktop Labelprinter

The ATP-300/600 Pro is Altec's Industrial Desktop Label printer. This is the successor to the TTP-200/300 series. This new label printer is technically improved and a lot more user-friendly. Placing media and printing labels is now easier and more advanced. Print 1001 types of labels with one and the same label printer.

Copyright information

Copyright Information © 2020 ALTEC industrial identification B.V.

The copyright in this manual, the software and firmware in the printer are owned by ALTEC industrial identification B.V. All rights reserved. Windows is a registered trademark of Microsoft Corporation. All other trademarks are the property of their respective owners.

Information in this document is subject to change without notice and does not represent a commitment on the part of ALTEC industrial identification B.V. No part of this manual may be reproduced or transmitted in any form or by any means, for any purpose other than the purchaser's personal use, without the expressed written permission of ALTEC industrial identification B.V.

Compliance and approvals



EN 55022, Class B
EN 55024
EN 60950-1



FCC part 15B, Class B



UL 60950-1



EN 60950-1



GB 4943.1
GB 9254
GB 17625.1

Battery safety warning

- Do not throw the battery in fire
- Do not short circuit the contacts
- Do not disassemble the battery
- Do not throw the battery in municipal waste

FCC Statement

This equipment has been tested and found to comply with the limits for a Class B digital device, pursuant to part 15 of the FCC Rules. These limits are designed to provide reasonable protection against harmful interference in a residential installation. This equipment generates, uses and can radiate radio frequency energy and, if not installed and used in accordance with the instructions, may cause harmful interference to radio communications. However, there is no guarantee that interference will not occur in a particular installation. If this equipment does cause harmful interference to radio or television reception, which can be determined by turning the equipment off and on, the user is encouraged to try to correct the interference by one or more of the following measures:

- Reorient or relocate the receiving antenna.
- Increase the separation between the equipment and receiver.
- Connect the equipment into an outlet on a circuit different from that to which the receiver is connected.
- Consult the dealer or an experienced radio/ TV technician for help.

This device complies with Part 15 of the FCC Rules. Operation is subject to the following two conditions: (1) This device may cause harmful interference, and (2) this device must accept any interference received, including interference that may cause undesired operation.

This Class B digital apparatus complies with Canadian ICES-003.

Cet appareil numérique de la classe B est conforme à la norme NMB-003 du Canada.

**CAUTION**

- Risk of explosion if battery is replaced by an incorrect type.
Dispose of used batteries according to the instructions.
- Any changes or modifications not expressly approved by the grantee of this device could void the user's authority to operate the equipment.
- Hazardous moving parts, keep fingers and other body parts away.

1.1 Product features

1.1.1 Standard features

The printer offers the following standard features:

Thermal transfer printing / Direct thermal printing

3,5" TFT LCD with 6 buttons

32-bit RISC CPU

Gap transmissive sensor (position adjustable)

Black mark reflective sensor (position adjustable)

See-through ribbon end sensor

Head open sensor

128MB Flash memory

Micro SD card reader for memory expansion, up to SDHC 32GB

RS-232 interface (Max. 115,200 bps)

USB 2.0 interface (Hi-speed mode)

Internal Ethernet print server (10/100 Mbps) interface

USB host

Real time clock & Buzzer

Standard industry emulations right out of the box including Eltron® and Zebra® language support

Internal 8 alpha-numeric bitmap fonts

Fonts and barcodes can be printed in any one of the four directions (0, 90,180, 270 degree)

Internal Monotype Imaging® true type font engine with one CG Triumvirate Bold Condensed scalable font

Downloadable fonts from PC to printer memory

Clean print head warning

Barcodes, graphics and image printing

1.1.2 Optional features

The printer offers the following optional features:

Peel-off kit

Industrial heavy duty cutter

Keyboard / Barcode scanner

External label roll mount

1.2 General specifications

Physical dimensions	226 mm (W) x 200 mm (H) x 332 mm (D)
Weight	4,08 KG (8,99 lbs)
Mechanism	Clamshell with double-walled plastic
Power	External power adapter - Input: AC 100-240V, 2.5A - Output: DC 24V/5.41A
Environmental condition	Operation: 5 ~ 40°C (41 ~ 104°F), 25~85% non-condensing Storage: -40 ~ 60 °C (-40 ~ 140°F), 10~90% non-condensing
Environmental concern	Comply with RoHS, WEEE

1.3 Print specifications

Print head resolution (dots per inch/mm)	ATP-300 Pro 300 dots/inch (12 dots/mm) ATP-600 Pro 600 dots/inch (24 dots/mm)
Printing method	Thermal transfer / Direct thermal
Dot size	ATP-300 Pro 0,084 x 0,084 mm (1 mm = 12 dots) ATP-600 Pro 0,042 x 0,042 mm (1 mm = 24 dots)
Print speed	Up to 6 inch/s (152 mm/s)
Max. print width	105,6 mm (4,15")
Max. print length	2.540 mm (100")

1.4 Ribbon specifications

Ribbon outside diameter	Max. 67 mm OD
Ribbon length	300 meter
Ribbon core inside diameter	25,4 mm (1") ID core
Ribbon width	40 mm ~ 110 mm
Wind direction	Coated Side Out (CSO)

1.5 Media specifications

Media roll capacity	Max. 125 mm (5") OD
Media core diameter	40 mm (1,5") ID core
Media type	Continuous, die-cut, black mark, external fan-fold, notch
Wind direction	Coated Side Out (CSO) / Coated Side In (CSI)
Media width	19 mm ~ 112 mm
Media thickness	0,055 mm ~ 0,254 mm
Black mark	Min. 8 mm (W) x 2 mm (H)
Gap height	Min. 2 mm

2 Product overview

2.1 Unpacking the printer

This printer has been specially packaged to withstand damage during shipping. Please carefully inspect the packaging and printer upon receiving the ATP-300/600 Pro printer. Please retain the packaging materials in case you need to reship the printer. Please check if the following items are included:

- ATP-300/600 Pro printer unit 1X
- Quick installation sheet 1X
- Power cord 1X
- Auto switch power supply 1X
- USB interface cable 1X
- Ribbon spindles 2X
- Paper core 1X



2.2 Printer overview

2.2.1 Front view



1. LCD display
2. Menu buttons
3. Metal tear-off bar
4. Top cover open lever
5. Power switch

2.2.2 Interior view

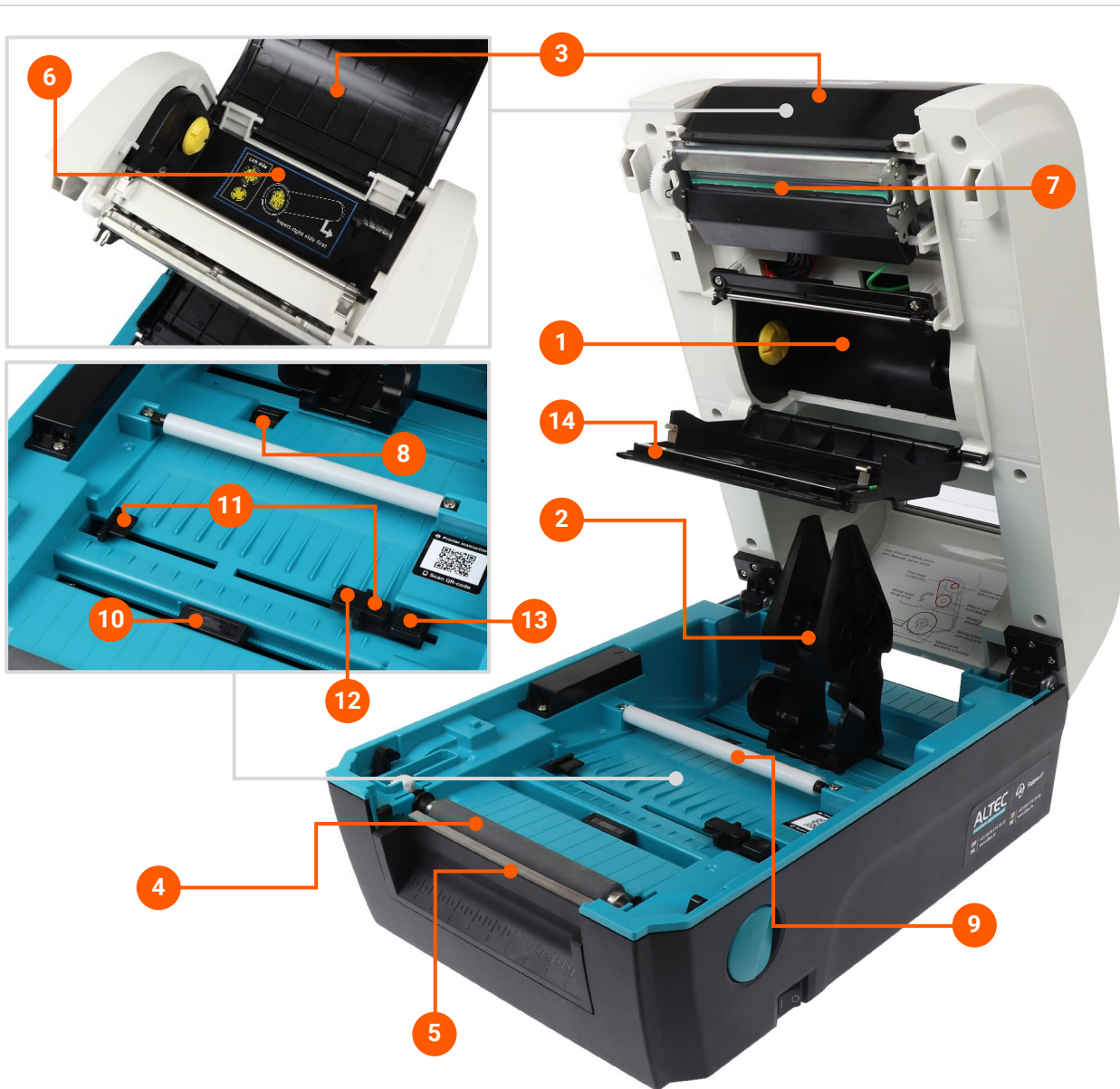

- | | | |
|------------------------|--------------------------------|-----------------------------------|
| 1. Ribbon supply hub | 6. Ribbon waste hub | 11. Black media guides |
| 2. Media holder | 7. Print head | 12. Gap transmissive sensor |
| 3. Ribbon access cover | 8. Media holder locking switch | 13. Media guide adjustment button |
| 4. Platen roller | 9. Media guide bar | 14. Ribbon supply cover |
| 5. Metal tear-off bar | 10. Black mark sensor | |

2.2.3 Rear view



- | | |
|-------------------------|---|
| 1. Power jack socket | 5. USB interface - connect to a PC |
| 2. Serial port (RS-232) | 6. USB host - connect to a keyboard / barcode scanner |
| 3. Ethernet interface | 7. MAC address identification label |
| 4. Micro SD card socket | 8. External label entrance |

3 Setup

3.1 Printer setup



1. Place the printer on a flat and secure surface



2. Make sure the **power switch** is turned off



3. Connect the printer to the computer with the provided **USB cable** (or an **ethernet cable**).



4. Plug the power cord into the **power cord socket** at the rear of the printer.

Then plug the power cord into a properly grounded power outlet.

3.2 Installing the ink ribbon



1. Open the top cover of the printer by pulling the **green levers** - located on each side of the printer - and lifting the top cover to the maximum open angle.

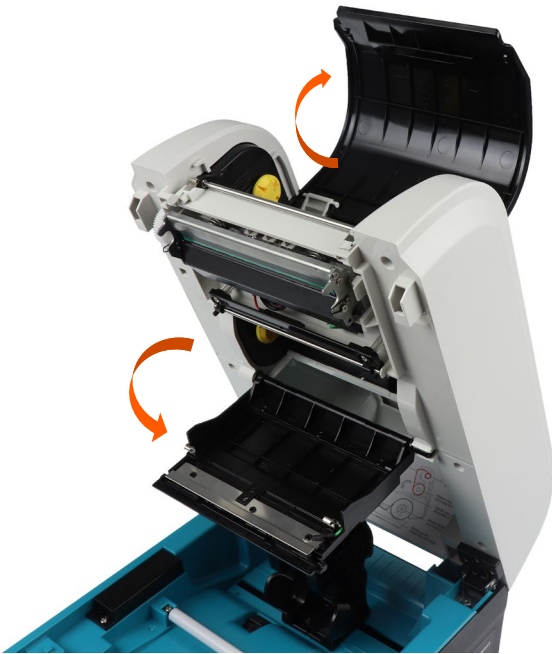

2. Open the **ribbon access cover** and the **ribbon supply cover**.

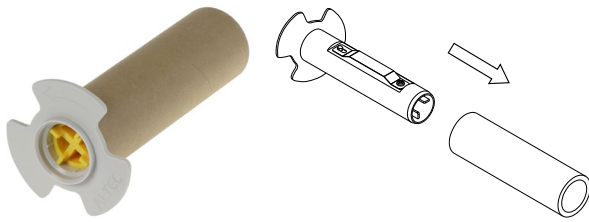

3. Insert a **ribbon spindle** into the paper core.



Do you have black ribbon spindles?

Request a new set of white ink ribbon spindles free of charge via +31(0)78 - 615 20 33 or info@altec.nl



4. Install the paper core with **the right side first** onto the ribbon rewind hub first.

Then align the (yellow) notches **on the left side** to mount it.

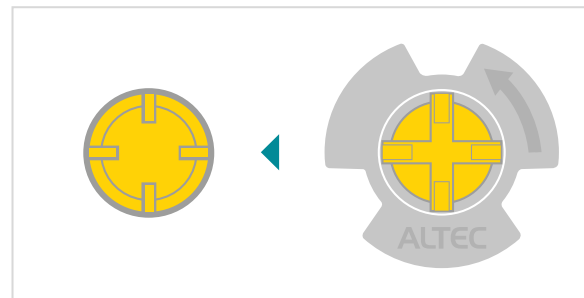

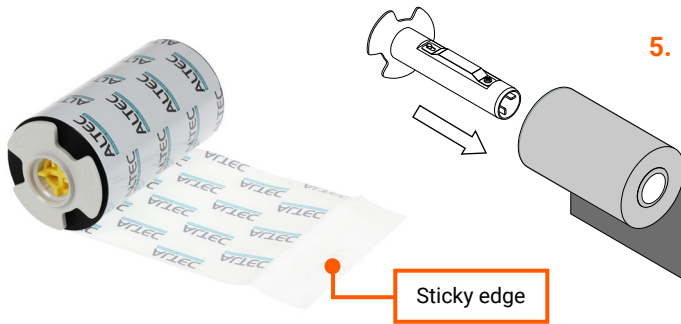

6. Install the ink ribbon with **the right side first** onto the ribbon supply hub first.

Then align the (yellow) notches **on the left side** to mount it.

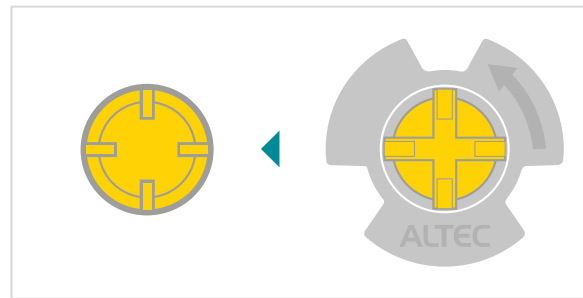



7. Stick the ink ribbon onto the (waste) paper core.

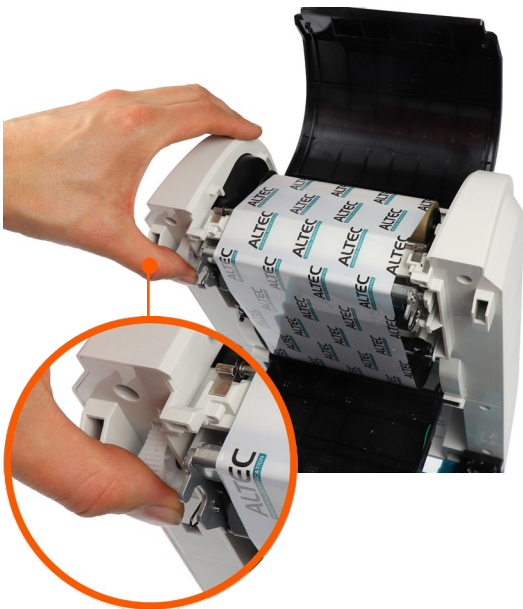

8. Turn the (waste) paper core with the (white) **ribbon rewind gear** until the plastic leader is thoroughly wound.

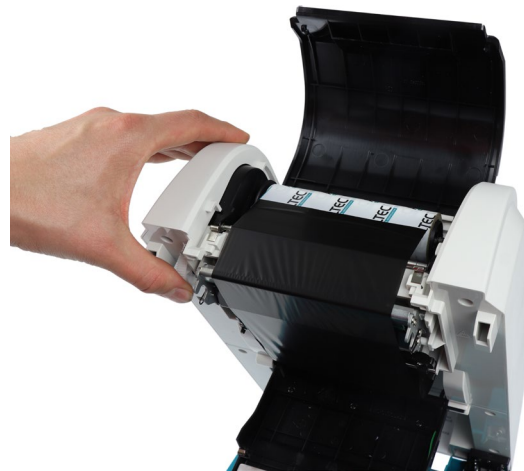

Close the top cover of the printer after installing the ink ribbon.



Instruction video

Learn how to install an ink ribbon with our instruction video.

[Watch video](#)

3.3 Loading media

3.3.1 Placing media in the printer



1. Open the top cover of the printer by pulling the **green levers** - located on each side of the printer - and lifting the top cover to the maximum open angle.

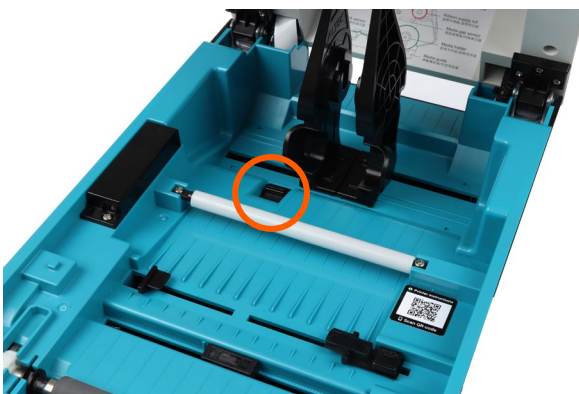

2. Make sure the (square) **lock** of the label holders is set to open.



3. Separate and hold the **media holders** open.



4. Place a roll of labels between the holders and close them onto the core.

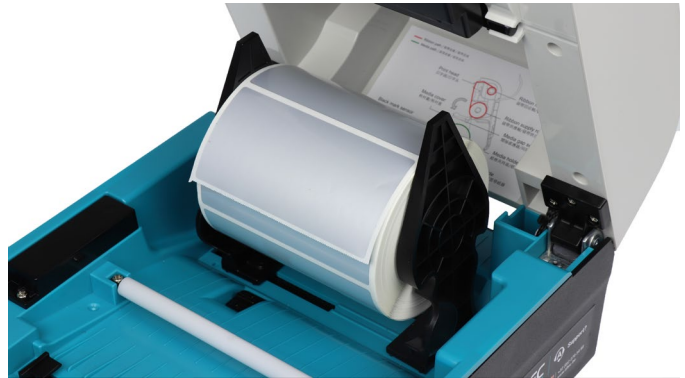

5. Lead the media under the white label guide bar.

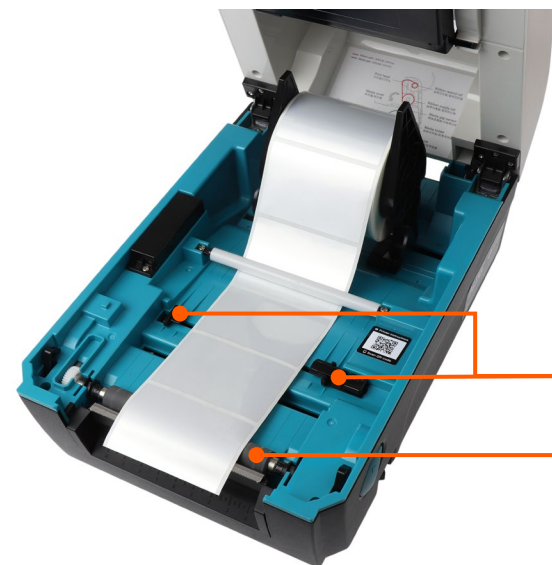

6. Place the media between the **black media guides** and place the label leading edge onto the **platen roller**.

Black media guides

Platen roller

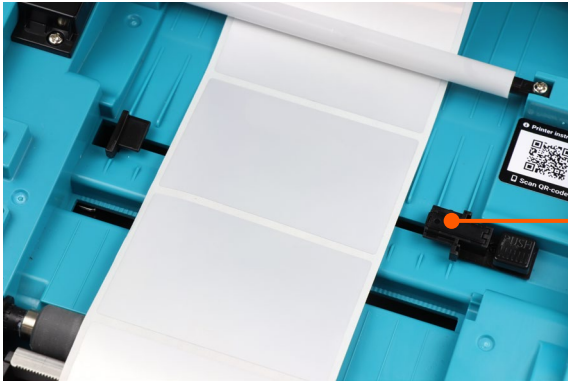

7. Move the **black media guides / gap sensor** to fit the media width by pushing the media guide adjustment button.

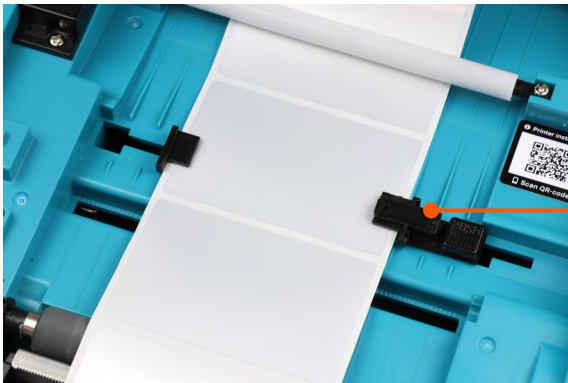

Please ensure that the black media guides are placed correctly:

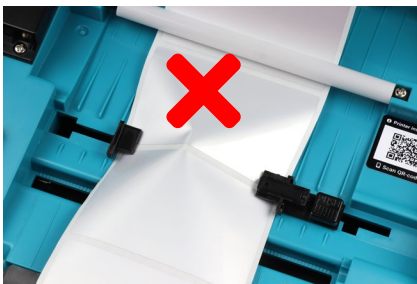

Too tight

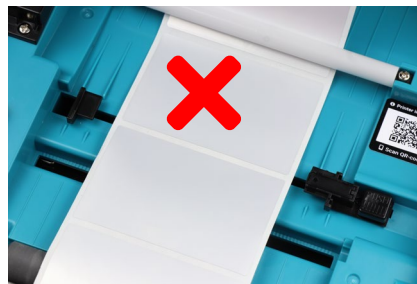

Too wide



Correct



Instruction video

Learn how to place media with our instruction video.

[Watch video](#)

3.3.2 Sensor setup



Labels with a **gap** (spacing)



Labels with a **notch** (cut out hole)



Continuous media (no detection)

A. Gap sensor

This is the most used sensor. Use this sensor when labels have a gap between them. This can be space between the labels or a (cut out) notch in the media.

Examples

- Nameplate labels
- Print&Laminate labels
- Print&Protect labels
- ResoPrint labels
- Self-laminating cable labels
- ADS Sleeves
- Industrial tags
- Component labels
- Welding label
- Paintlabel
- ToughSurface
- Industrial vinyl
- Inspection labels
- Laboratory labels
- Continuous media



Labels with a **notch** out of range of gap sensor



Black mark sensor
The two small dots are the sensor

Example of media with **black marks**



B. Black mark sensor

Use the black mark sensor when a media has a notch that is out of range of the gap sensor - or when media has black marks on the back of the label.

Position this sensor accurately under the notch of the label. The two small dots of the sensor should be exactly under the gap.

Examples

- ADC Cable markers
- Cable flags
- Standard sleeves
- Wire tags
- P- & T- labels
- Repositionable cable labels
- Lockout / Tagout tags
- High temperature tags
- Magnetic labels

Close the top cover of the printer after loading the media and setting up the sensor.

4 LCD display menu



4.1 LCD display

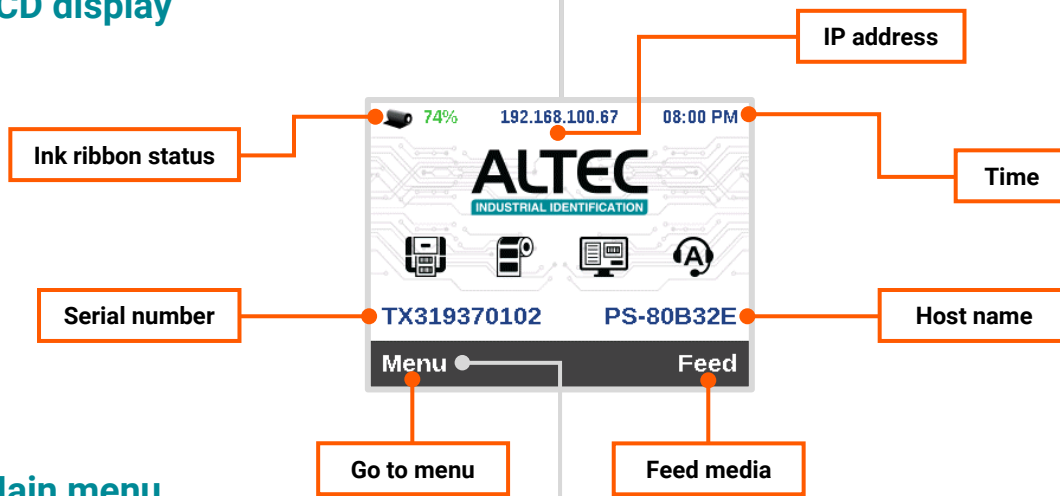

4.2 Main menu

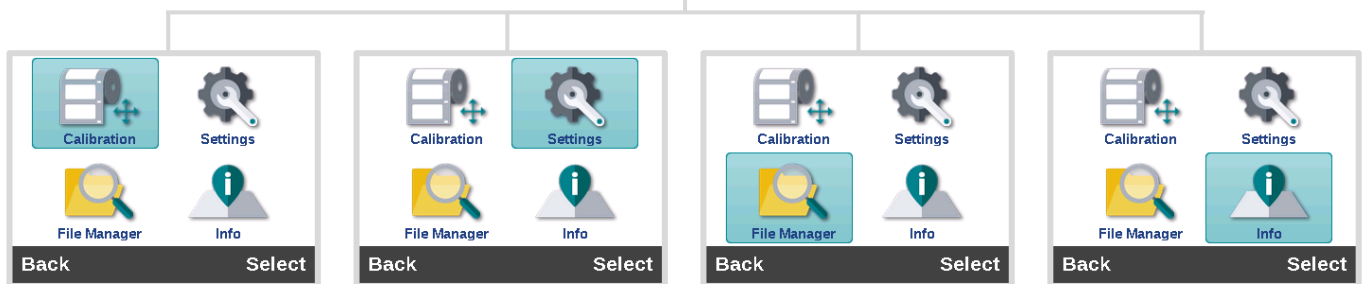

Calibration

- Auto calibration
- Manual setup
- Threshold detect
- Maximum length

Settings

- 1st label adjustment
- Interface
- Diagnostic
- Advanced
- Factory default

File manager

- DRAM
- FLASH
- CARD
- USB

Info

- Instruction videos
- Printer info
- Contact details

4.3 Calibration

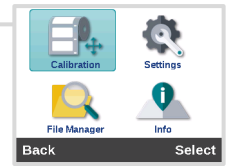

4.3.1 Auto calibration

The printer will feed 2 to 3 labels to calibrate the sensor automatically.

Gap

Use this method when labels have a gap between them.

This can be space between the labels or a (cut out) notch in the media.

<p>Calibration</p> <ul style="list-style-type: none"> Auto Calibration > Manual Setup > Threshold Detect Auto Maximum Length 254 mm <p>Back Select</p>	<p>Auto Calibration</p> <ul style="list-style-type: none"> Gap > Black Mark > Continuous > <p>Back Select</p>	<p>Auto Calibration</p> <ul style="list-style-type: none"> Gap Information > Black Mark > Continuous > <p>Calibrating</p> <p>Back Pause</p>	<p>Auto Calibration</p> <ul style="list-style-type: none"> Gap Information > Black Mark > Continuous > <p>Calibration complete</p> <p>Back Pause</p>
---	--	--	---

1 Auto Calibration 2 Gap 3 Calibrating 4 Calibration complete

Black mark

Use this method when a media has a notch that is out of range of the gap sensor - or when media has black marks on the back of the label.

<p>Calibration</p> <ul style="list-style-type: none"> Auto Calibration > Manual Setup > Threshold Detect Auto Maximum Length 254 mm <p>Back Select</p>	<p>Auto Calibration</p> <ul style="list-style-type: none"> Gap > Black Mark > Continuous > <p>Back Select</p>	<p>Auto Calibration</p> <ul style="list-style-type: none"> Gap Information > Black Mark > Continuous > <p>Calibrating</p> <p>Back Pause</p>	<p>Auto Calibration</p> <ul style="list-style-type: none"> Gap Information > Black Mark > Continuous > <p>Calibration complete</p> <p>Back Pause</p>
---	--	--	---

1 Auto Calibration 2 Black Mark 3 Calibrating 4 Calibration complete

Continuous

Use this method for continuous media (A320 Industrial Vinyl for example)

<p>Calibration</p> <ul style="list-style-type: none"> Auto Calibration > Manual Setup > Threshold Detect Auto Maximum Length 254 mm <p>Back Select</p>	<p>Auto Calibration</p> <ul style="list-style-type: none"> Gap > Black Mark > Continuous > <p>Back Select</p>	<p>Auto Calibration</p> <ul style="list-style-type: none"> Gap Information > Black Mark > Continuous > <p>Calibrating</p> <p>Back Pause</p>	<p>Auto Calibration</p> <ul style="list-style-type: none"> Gap Information > Black Mark > Continuous > <p>Calibration complete</p> <p>Back Pause</p>
---	--	--	---

1 Auto Calibration 2 Continuous 3 Calibrating 4 Calibration complete

4.3.2 Manual Setup

In case **Auto Calibration** does successfully detect your media, please use the **Manual Setup** function to calibrate the sensor sensitivity.

Gap

Calibrate the gap sensor on your media manually.

1 Manual Setup	2 Gap	3 Scan Backing	4 Scan Paper
5 Intensity and Threshold	6 Get Label Length - Yes		

How to scan Backing?

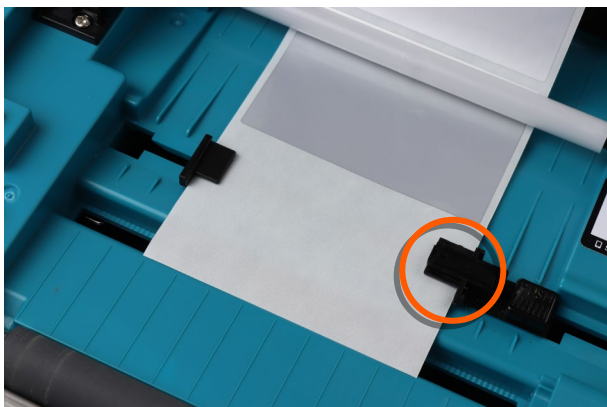

Remove one label from the backing and place the backing under the gap sensor

How to scan Paper?

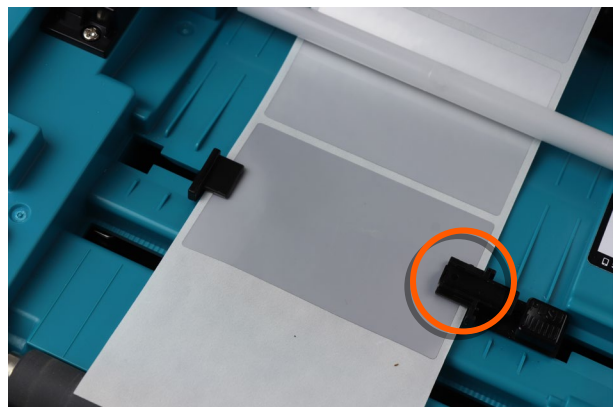

Place the media under the gap sensor

Black Mark

Calibrate the Black mark sensor on your media manually.

<p>Calibration</p> <p>Auto Calibration ></p> <p>Manual Setup ></p> <p>Threshold Detect Auto</p> <p>Maximum Length 254 mm</p> <p>Back Select</p>	<p>Manual Setup</p> <p>Gap ></p> <p>Black Mark ></p> <p>Continuous ></p> <p>Back Select</p>	<p>Manual Setup</p> <p>Gap ? Black Mark ></p> <p>Blac ? Scan Mark ></p> <p>Con ? 213 ></p> <p>Back Select</p>	<p>Manual Setup</p> <p>Gap ? Black Mark ></p> <p>Blac ? Scan Paper ></p> <p>Con ? 708 ></p> <p>Back Select</p>
<p>1 Manual Setup</p>	<p>2 Black Mark</p>	<p>3 Scan Mark</p>	<p>4 Scan Paper</p>
<p>Manual Setup</p> <p>Gap Complete ></p> <p>Blac Intensity 8 ></p> <p>Con Threshold 575 ></p> <p>Back Select</p>	<p>Manual Setup</p> <p>Gap ? Get Label Length ></p> <p>Blac Yes ></p> <p>Con No ></p> <p>Back Select</p>		
<p>5 Intensity and Threshold</p>	<p>6 Get Label Length - Yes</p>		

How to scan Mark?

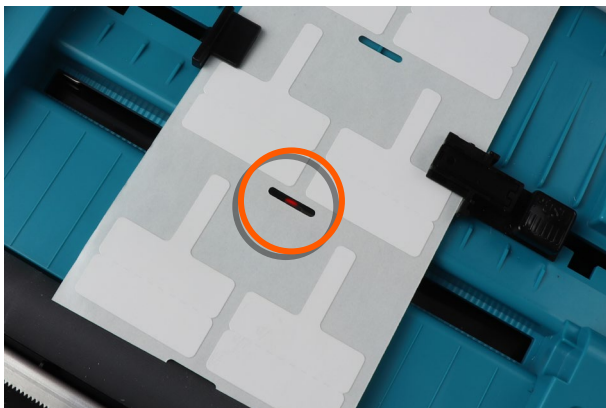

Place the notch (or mark) exactly on the two round dots of the Black mark sensor.



How to scan Paper?

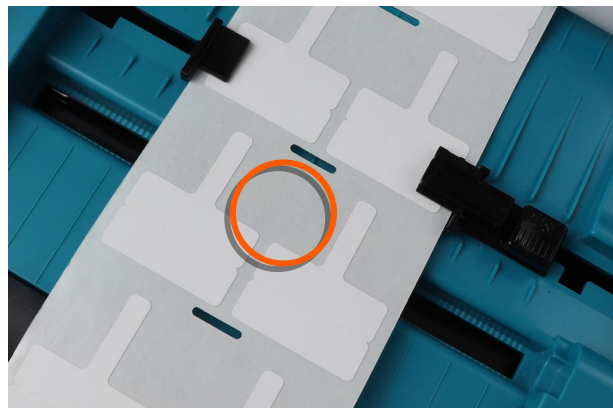

Place the backing of the media on the Black mark sensor



Media with black marks?
Place the black mark exactly on the Black mark sensor

Continuous

Calibrate the gap sensor on your continuous media manually.

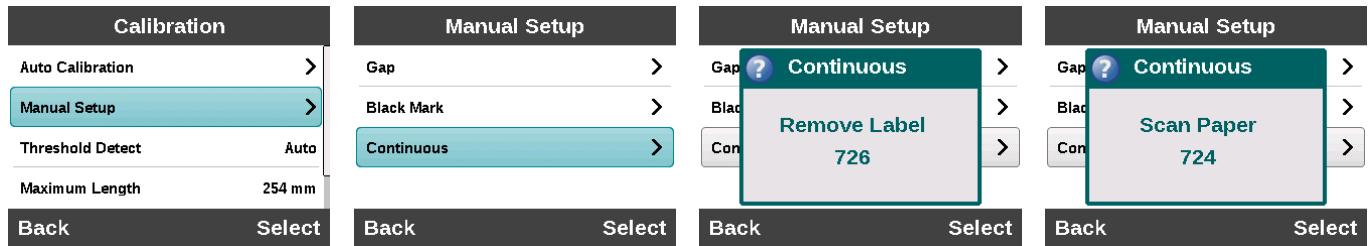

1 Manual Setup

2 Gap

3 Remove Label

4 Scan Paper

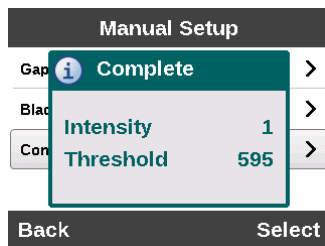

5 Intensity and Threshold

Remove label

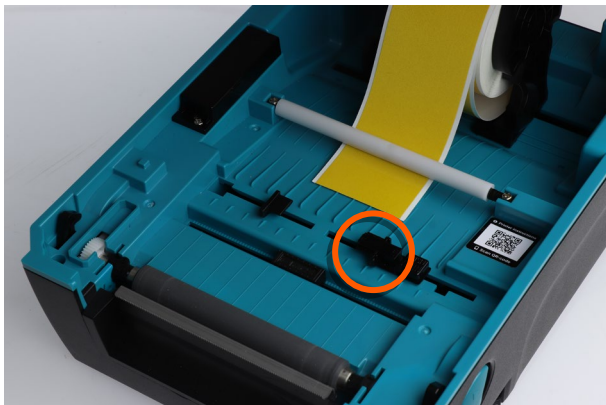

Remove continuous media from the gap sensor

How to scan Paper?

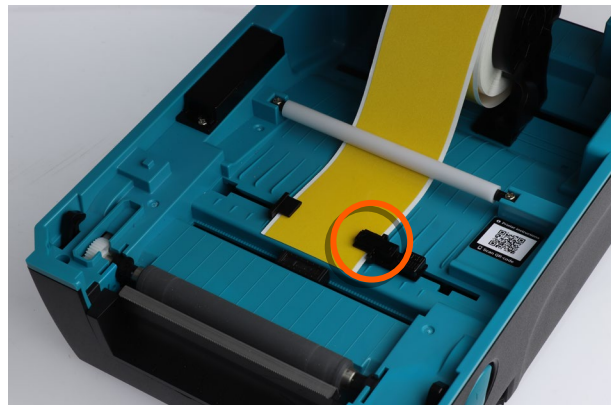

Place continuous media under the gap sensor

4.3.3 Threshold detect

This option is used to set the sensor sensitivity to **fixed** or **auto** (default = auto).

Calibration	Threshold Detect	Threshold Detect
Auto Calibration >	▲	▲
Manual Setup >	Auto	Fixed
Threshold Detect Auto	▼	▼
Maximum Length 254 mm	Back	Back
Select	Select	Select

1 Threshold Detect **2A** Option 1: Auto **2B** Option 2: Fixed

4.3.4 Maximum length

This option is used to set the maximum length for media calibration.

Calibration	Maximum Length
Auto Calibration >	+ + + +
Manual Setup >	0 2 5 4 mm
Threshold Detect Auto	- - - -
Maximum Length 254 mm	Back
Select	Select

1 Maximum Length **2** Set length

4.3.5 Advanced

Enable / Disable the advanced functions.

Calibration	Calibration
Manual Setup >	Manual Setup >
Threshold Detect Auto	Threshold Detect Auto
Maximum Length 254 mm	Maximum Length 254 mm
Advanced OFF	Advanced ON
Back	Back
Select	Select

A Advanced - OFF (Disabled) **B** Advanced - ON (Enabled)

4.3.6 Minimum paper length (advanced)

Set the minimum paper length to auto-calibrate the sensor sensitivity.

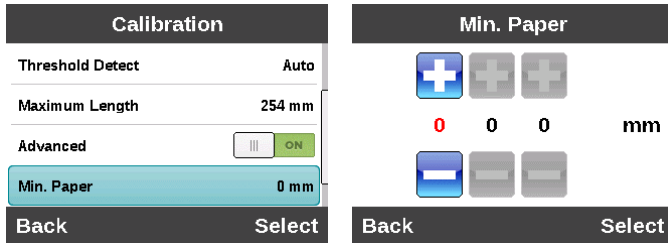

1 Min. Paper

2 Set min. paper length

4.3.7 Maximum paper length (advanced)

Set the maximum gap / black mark length to auto-calibrate the sensor sensitivity.

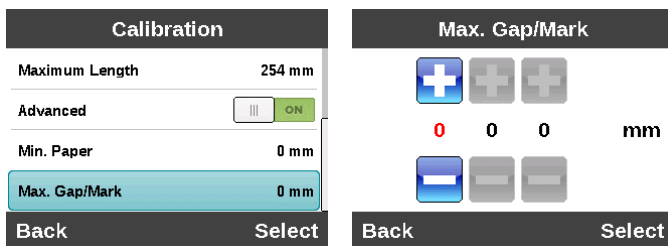

1 Max. gap / mark

2 Set max. gap / mark

4.4 Settings

4.4.1 1st label adjustment

This option is used to set the amount of dots to adjust the first label of the print job.

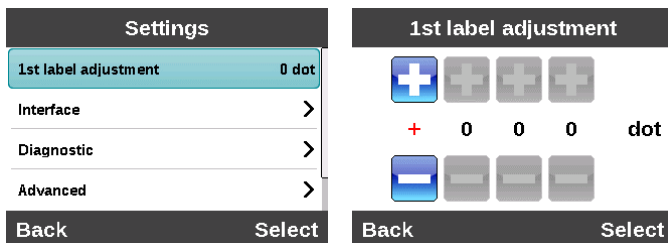
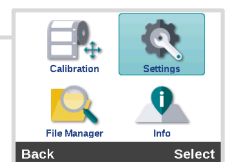

1 1st label adjustment

2 Set the amount of dots

Reference

ATP-300 Pro (300 DPI)
ATP-600 Pro (600 DPI)









1 mm = 12 dots
1 mm = 24 dots

4.4.2 Interface

This option is used to set the printer interface settings.

Serial

Set the baud rate, parity, data bits and stop bit(s).

Settings	Interface	Serial	Baud Rate
1st label adjustment 0 dot	Serial >	Baud Rate 9600 bps	 9600 bps 
Interface >	Ethernet >	Parity None	Back Select
Diagnostics >		Data Bits 8	
Advanced >		Stop Bit(s) 1	
Back Select	Back Select	Back Select	Back Select
1 Interface	2 Serial	3A Baud rate	4A Set baud rate
		Baud Rate 9600 bps	
		Parity None	 Even 
		Data Bits 8	Back Select
		Stop Bit(s) 1	
		Back Select	4B Set parity
		3B Parity	
		Baud Rate 9600 bps	
		Parity None	
		Data Bits 8	 8 
		Stop Bit(s) 1	Back Select
		Back Select	4C Set data bits
		3C Data Bits	
		Baud Rate 9600 bps	
		Parity None	
		Data Bits 8	
		Stop Bit(s) 1	 1 
		Back Select	Back Select
		3D Stop Bit(s)	4D Set stop bit(s)

Ethernet

Use this menu to set the Ethernet configuration or check the Ethernet status.

Settings	Interface
1st label adjustment 0 dot	Serial >
Interface >	Ethernet >
Diagnostics >	
Advanced >	
Back Select	Back Select

1 Interface **2** Ethernet

Status

Check the Ethernet status.

Ethernet	Status
Status 192.168.100.175	MAC Address 001B82-80B33C
Configure DHCP	IP Address 192.168.100.175
	Subnet Mask 255.255.255.0
	Default Gateway 192.168.100.1
Back Select	Back

3A Check status **4A** Ethernet status

Configure

Ethernet configuration for DHCP or Static IP.

DHCP

Ethernet	Ethernet	Ethernet
Status 192.168.100.175	Status ? Configure 192.168.100.175	Status ? DHCP 192.168.100.175
Configure DHCP	Configure DHCP / Static IP	Configure Yes / No
Back Select	Back Select	Back Select

3B Configure **4B** Choose DHCP **5B** Yes - To set DHCP

Static IP

The screenshots show the following steps:

- 3C Configure:** Ethernet status page showing IP 192.168.100.175 and DHCP status. A 'Configure' button is highlighted.
- 4C Choose Static IP:** 'Configure' dialog box with 'Static IP' selected.
- 5C Set IP Address:** 'IP Address' page with numeric keypad showing 192.168.100.175.
- 6C Set Subnet mask:** 'Subnet Mask' page with numeric keypad showing 255.255.255.000.
- 7C Set Default gateway:** 'Default Gateway' page with numeric keypad showing 010.100.101.253.
- 8C Yes - Set static IP:** 'Static IP' dialog box with 'Yes' selected.

4.4.3 Diagnostics

Print configuration

This feature is used to print the current printer configuration on the media. Please use media with a minimum width of 50mm (preferably 100mm).

The screenshots show the following steps:

- 1 Diagnostic:** 'Settings' menu with 'Diagnostic' selected.
- 2 Print configuration:** 'Diagnostic' menu with 'Print Config.' selected.
- 3 Printing:** 'Diagnostic' menu with 'Information' selected, showing 'Printing 1/1'.

A photograph shows the printer outputting a printed configuration page.

The printout contains the following information

System information	Printing settings	ZPL setting information	Connection information
<ul style="list-style-type: none"> Model Model name Firmware Firmware version Checksum Firmware checksum S/N Printer serial number TCF Configuration file Date System date Time System time TPH Printed mileage CUT Cutting counter 	<ul style="list-style-type: none"> Speed Print speed (inch/s) Density Printing temperature Width/Height Media size Gap Gap distance Intension Sensor intension Codepage Code page Country Country code 	<ul style="list-style-type: none"> Darkness Print darkness Speed Print speed (inch/s) Width Media size Tilde Control prefix Caret Format prefix Delimiter Delimiter prefix Power up Power up motion Head close Head close motion 	<ul style="list-style-type: none"> RS-232 Baud, Parity, Data bit, Stop bit Ethernet Name, MAC-address, IP-address, Subnet, Gateway, Port <p>Memory information</p> <ul style="list-style-type: none"> DRAM Numbers of download files + total and available memory space FLASH

Dump mode

Captures the data from the communications port and prints out the data received by the printer. In the dump mode, all data will be printed in two columns. The left side characters are received from your system and the right side characters are the corresponding hexadecimal values of the characters. It allows users to verify and debug the data received by the printer. To leave dump mode, please restart the printer.

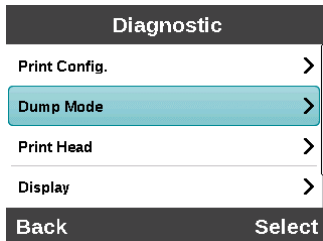

1 Dump mode

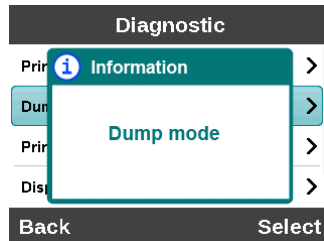

2 Dump mode activated

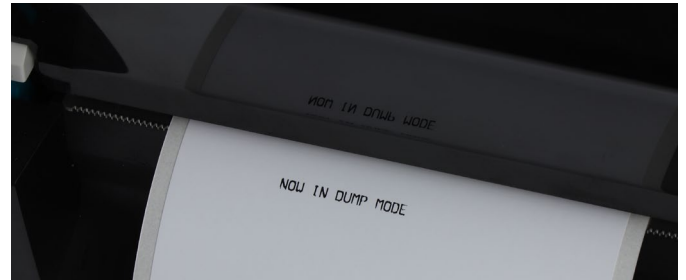

Print head

This feature is used to check the print head temperature, resistance and bad dots.

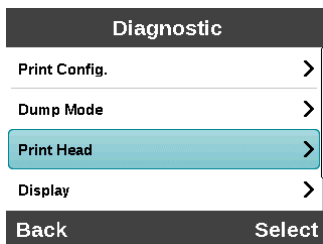

1 Print head

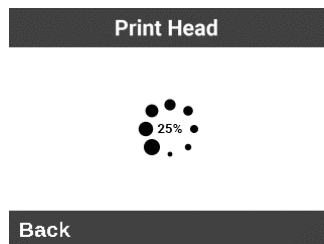

2 In progress

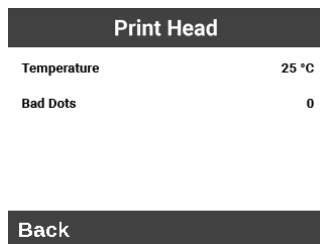

3 Print head status

Display

This feature is used to check the LCD's color state.

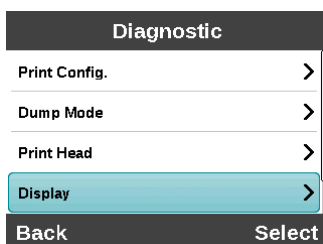

1 Display

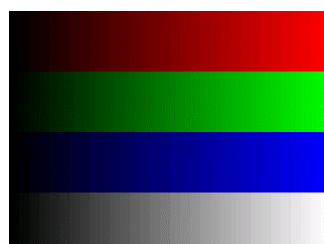

2 Check the display colors

Sensor

This feature is used to check the media sensor state.

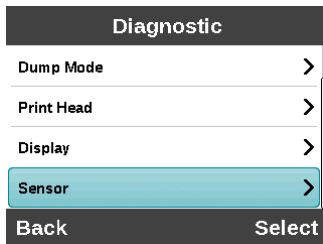

1 Sensor

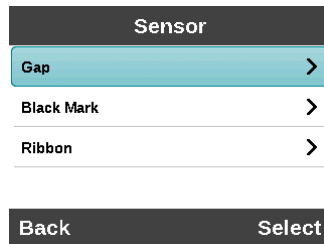

2A Gap sensor



3A Check / Adjust gap sensor

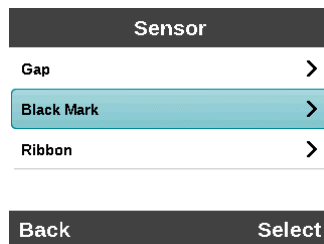

2B Black mark sensor

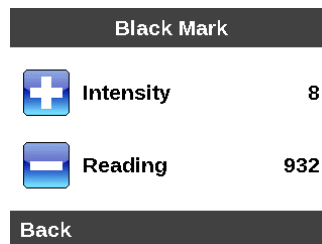

3B Check / Adjust black mark sensor

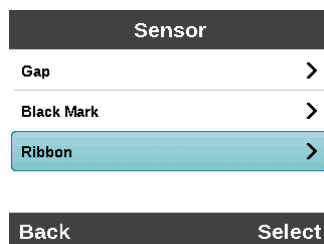

2C Ribbon sensor



3C Check / Adjust ribbon sensor

4.4.4 Advanced

This feature is used to set the LCD display brightness, date & time, language and sound.

Display brightness

Set the LCD display brightness

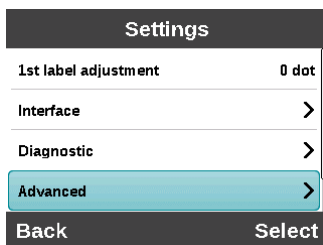

1 Advanced

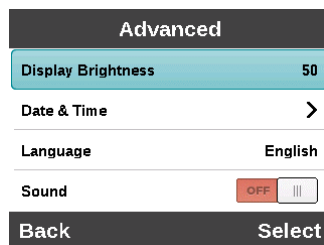

2 Display brightness

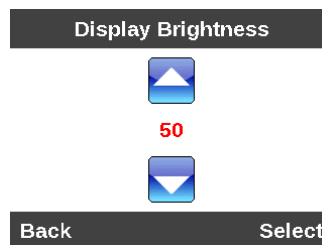

3 Set the display brightness

Date & Time

Set date, time and time format.

Settings	
1st label adjustment	0 dot
Interface	>
Diagnostic	>
Advanced	>
Back	Select



1 Advanced

Advanced	
Display Brightness	50
Date & Time	>
Language	English
Sound	OFF III
Back	Select

2 Date & Time

Date & Time	
Date Format	YYYY/MM/DD
Time Format	12 Hour
Date	2007/01/08
Time	00:54:17
Back	Select



3A Date format

Date Format	
 YYYY/MM/DD 	
Back	Select

4A Set Date format

Date & Time	
Date Format	YYYY/MM/DD
Time Format	12 Hour
Date	2007/01/08
Time	00:54:07
Back	Select







3B Time format

Time Format	
 12 Hour 	
Back	Select

4B Set time format

Date & Time	
Date Format	YYYY/MM/DD
Time Format	12 Hour
Date	2007/01/08
Time	00:53:51
Back	Select







3C Date

Date		
   2020 - 02 - 21   		
Back	Select	

4C Set date

Date & Time	
Date Format	YYYY/MM/DD
Time Format	12 Hour
Date	2007/01/08
Time	00:53:57
Back	Select

3D Time

Time		
   02 : 24 : 24   		
Back	Select	

4D Set time

Language

Set the language of the printer to English, German, Dutch or French.

Settings	
1st label adjustment	0 dot
Interface	>
Diagnostic	>
Advanced	>
Back	Select

1 Advanced

Advanced	
Display Brightness	50
Date & Time	>
Language	English
Sound	OFF III
Back	Select

2 Language

Language	
English	✓
Deutsch	
Nederlands	
Français	
Back	Select

3 Set a language

Print Quality (ATP-600 Pro only)

Set the print quality to Standard or Power mode. Power mode improves the print quality on specific label materials. This setting is only available on the ATP-600 Pro.

Settings	Advanced	Print Quality
1st label adjustment 0 dot	Language English	▲
Interface >	Sound <input type="checkbox"/> ON	Standard
Diagnostic >	Print Quality Standard	▼
Advanced >	Density Base 0	Back Select
Back Select	Back Select	

1 Advanced **2** Print Quality **3A** Standard

Print Quality
▲
Power
▼
Back Select

3B Power

Sound

Turn the printer sound on or off.

Settings	Advanced	Advanced
1st label adjustment 0 dot	Display Brightness 50	Display Brightness 50
Interface >	Date & Time >	Date & Time >
Diagnostic >	Language English	Language English
Advanced >	Sound <input type="checkbox"/> OFF	Sound <input type="checkbox"/> ON
Back Select	Back Select	Back Select

1 Advanced **2A** Sound OFF **2B** Sound ON

Density base

Increase or decrease the base density. Use this functionality only at the request of Altec.

Settings	Advanced	Density Base
1st label adjustment 0 dot	Date & Time >	▲
Interface >	Language English	0
Diagnostic >	Sound <input type="checkbox"/> OFF	▼
Advanced >	Density Base 0	Back Select
Back Select	Back Select	

1 Advanced **2** Density Base **3** Set density base

4.4.5 Factory default

Initialize the printer and restore the settings to factory default.

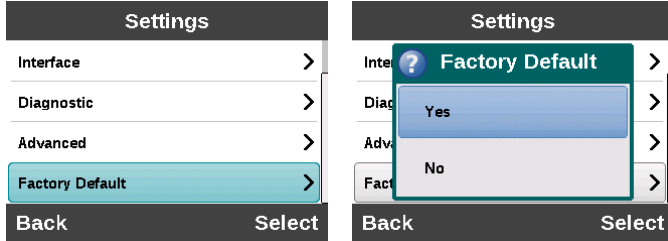

- 1** Factory default
- 2** Yes - Factory default

4.5 File manager

This feature is used to check the printer available memory and file list on **DRAM, FLASH, CARD** and **USB**. Show, delete and run (.BAS) files saved on the memory device.

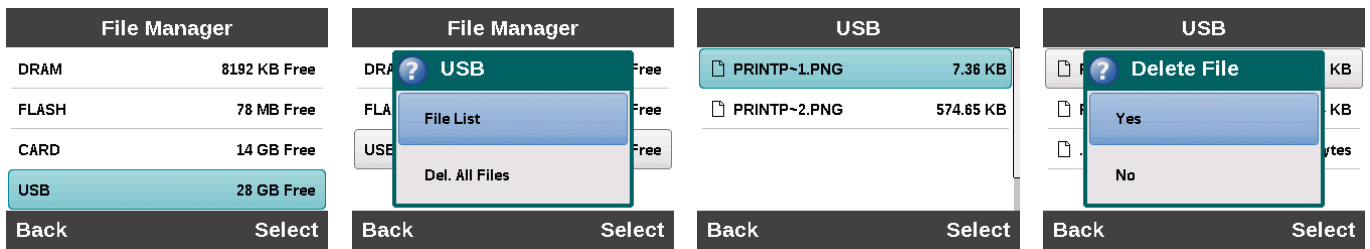
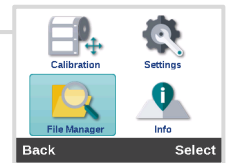

- 1** File Manager
- 2A** To file list
- 3A** File list
- 4A** Select > Yes - delete file

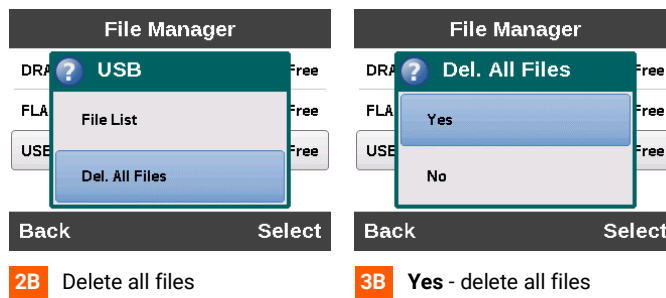

- 2B** Delete all files
- 3B** Yes - delete all files



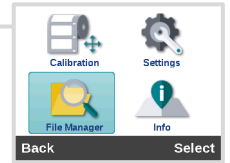

4.6 Info

This menu feature provides printer information, contact details and QR-codes to instruction videos.



4.6.1 Instruction videos

Scan the QR-codes on the LCD display to view instruction videos on your smartphone.

<p>Info</p> <ul style="list-style-type: none"> Instruction Videos > Printer Info > Contact Details > <p>Back Select</p>	<p>Instruction Videos</p> <ul style="list-style-type: none"> Installing Labels > Installing Ribbon > Cleaning Platen Roller > General Maintenance > <p>Back Select</p>	<p>Installing Labels</p>  <p>Please scan this QR-code or visit www.qr-altec.nl/ATP-600</p> <p>Back</p>
<p>1 Instruction videos</p>	<p>2A Installing labels</p>	<p>3A Scan QR-code</p>
<p>Info</p> <ul style="list-style-type: none"> Installing Labels > Installing Ribbon > Cleaning Platen Roller > General Maintenance > <p>Back Select</p>	<p>Instruction Videos</p> <ul style="list-style-type: none"> Installing Labels > Installing Ribbon > Cleaning Platen Roller > General Maintenance > <p>Back Select</p>	<p>Installing Ribbon</p>  <p>Please scan this QR-code or visit www.qr-altec.nl/ATP-600</p> <p>Back</p>
<p>2B Installing ribbon</p>	<p>2B Installing ribbon</p>	<p>3B Scan QR-code</p>
<p>Info</p> <ul style="list-style-type: none"> Installing Labels > Installing Ribbon > Cleaning Platen Roller > General Maintenance > <p>Back Select</p>	<p>Instruction Videos</p> <ul style="list-style-type: none"> Installing Labels > Installing Ribbon > Cleaning Platen Roller > General Maintenance > <p>Back Select</p>	<p>Cleaning Platen Roller</p>  <p>Please scan this QR-code or visit www.qr-altec.nl/ATP-600</p> <p>Back</p>
<p>2C Cleaning platen roller</p>	<p>2C Cleaning platen roller</p>	<p>3C Scan QR-code</p>
<p>Info</p> <ul style="list-style-type: none"> Installing Labels > Installing Ribbon > Cleaning Platen Roller > General Maintenance > <p>Back Select</p>	<p>Instruction Videos</p> <ul style="list-style-type: none"> Installing Labels > Installing Ribbon > Cleaning Platen Roller > General Maintenance > <p>Back Select</p>	<p>General Maintenance</p>  <p>Please scan this QR-code or visit www.qr-altec.nl/ATP-600</p> <p>Back</p>
<p>2D General maintenance</p>	<p>2D General maintenance</p>	<p>3D Scan QR-code</p>

4.6.2 Printer info

View printer info: serial number, mileage, printed labels and cutting counter.

Info	Printer Info
Instruction Videos >	Serial No. TX319370130
Printer Info >	Mileage (m)(m.) 136
Contact Details >	Labels (pcs.) 1919
	Cutting Counter 232
Back Select	Back
1 Printer info	2 View printer info

4.6.3 Contact details

View the contact details of ALTEC industrial identification.

Info	Contact Details
Instruction Videos >	 Nederland T. +31 (0)78 615 20 33 • www.altec.nl België / Belgique T. +32 (0)2 270 34 88 • www.altec.be
Printer Info >	
Contact Details >	
Back Select	Back
1 Contact details	2 View contact details

4.7 Errors and messages

Carriage open

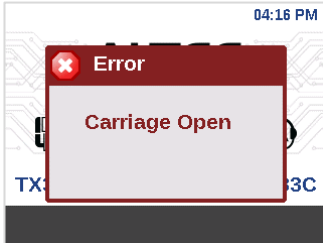

The top cover of the printer is open. Make sure the top cover is closed properly.

Please calibrate the printer



This error can mean the following:

- **Out of media**
Install new roll of media ([3.3.1](#))
- **No media**
Install (new) roll of media ([3.3.1](#))
- **Check sensor type**
[Go to chapter 3.3.2](#)
- **Calibration required**
[Go to chapter 4.3](#)

No Ribbon

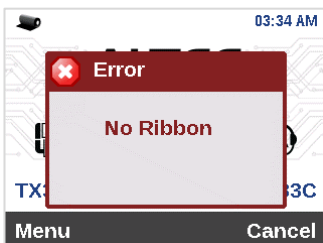

No ribbon installed or the ink ribbon has run out. [Go to chapter 3.2.](#)

Can't calibrate

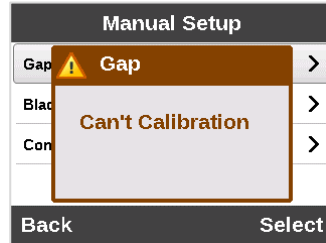

A problem has occurred while calibrating your media.

[Please follow the steps in chapter 4.3.](#)

Question

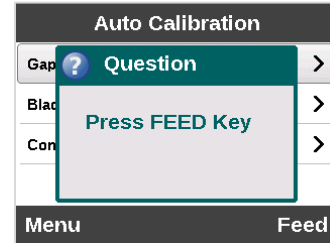

Press the feed button on the printer to feed the media.

5 Printer Web Interface

The ATP-300/600 Pro can be accessed via a web browser if it is connected with an Ethernet cable. In this menu you can access printer information and change settings.

5.1 Accessing the Printer Web Interface

Open a web browser and enter the **IP address** (or host name) of the printer in the address bar.

Important the web interface can only be accessed if the printer is connected with an Ethernet cable

You can find the **IP address** and **host name** on the LCD display of the printer.

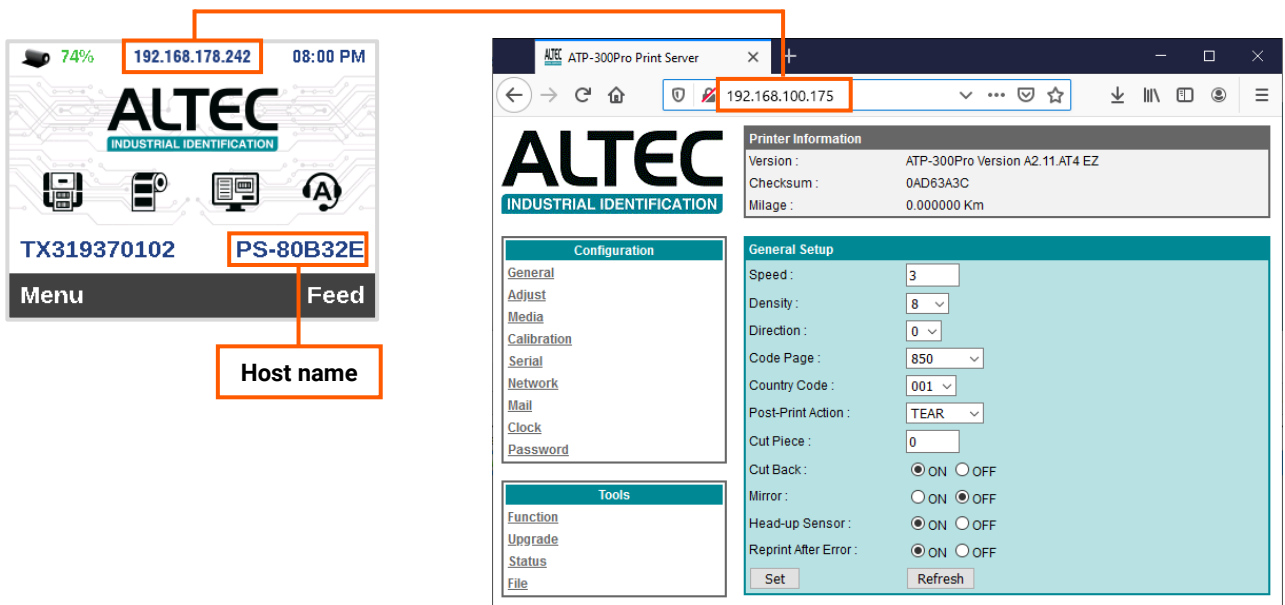

5.2 Configuration

General

Change general printer settings

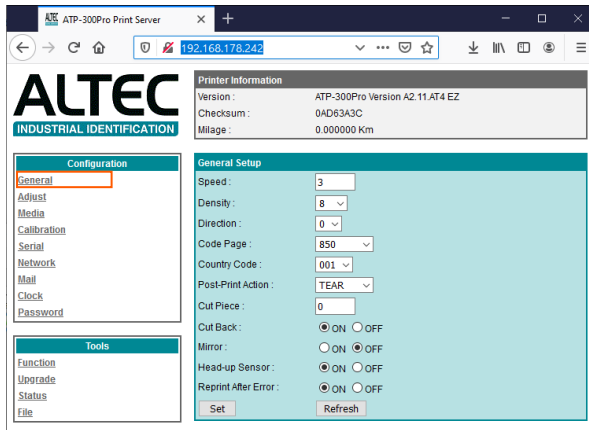

Speed

Printer speed (1.5 – 6 inch/s)

Density

Printing temperature (0 - 15)

Direction

Print direction (0 or 1)

Code Page

Keyboard country code

Post-Print action

TEAR / PEAL / CUTTER / OFF

Cut Piece

Cut after "X" labels

Cut Back

Return media after cutting

Mirror

Mirrored printing

Head-up Sensor

Top cover open/closed check

Reprint After Error

Reprint last label after error

Adjust

Set the print and tear-off position

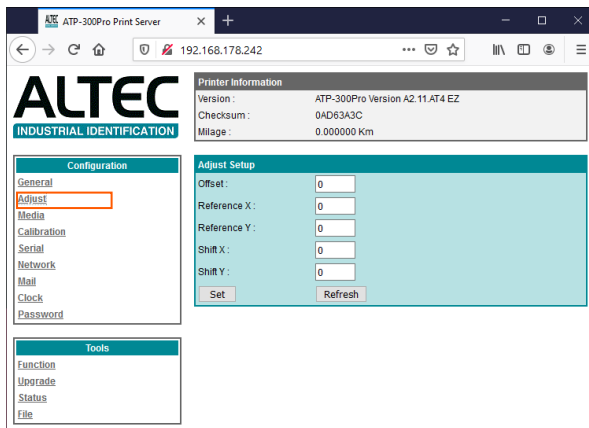

Offset

Adjust tear-off position

Reference X / Y

Adjust print and tear-off position

Shift X / Y

Adjust print position

Media

Label and printer sensor settings

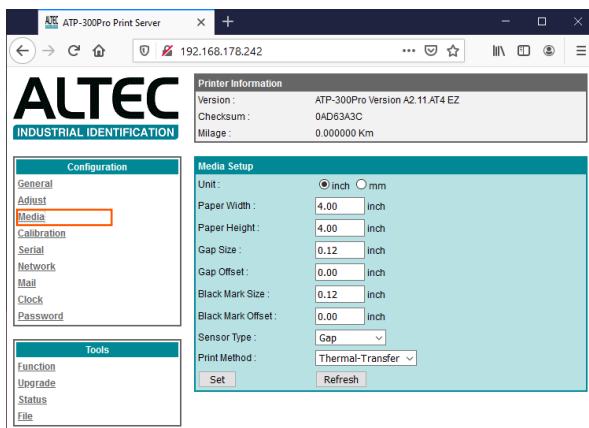

Unit

Set unit to inch or mm

Paper width

Media width in millimeters

Paper height

Media height in millimetres

Gap Size

Gap size (height) in millimeters

Gap Offset

Offset distance in millimetres

Black Mark Size

Black Mark size (height) in millimeters

Black Mark Offset

Offset distance in millimetres

Sensor Type

Gap / Black mark / Continuous

Print Method

Thermal-Transfer / Direct thermal

Calibration

Change calibration settings

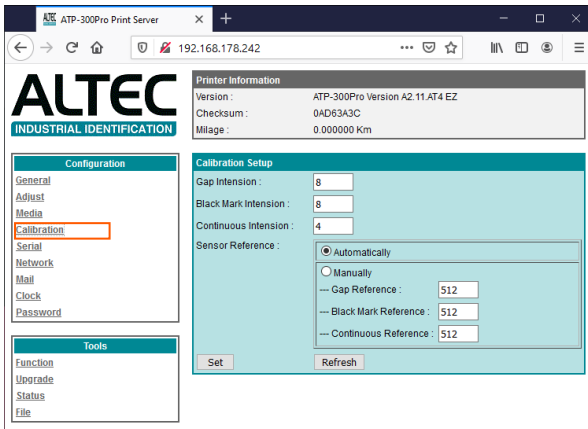

Advanced settings for the sensor intension and sensor reference.

Serial

Port settings for serial connection (RS232)

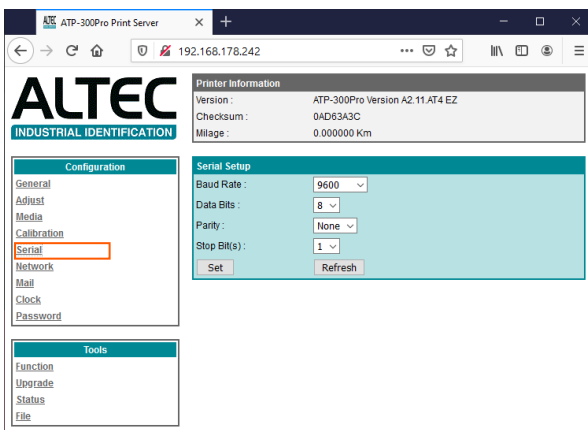

Port settings for the RS232 serial port

- Baud rate
- Data bits
- Parity
- Stop bit(s)

Network

Apply network settings

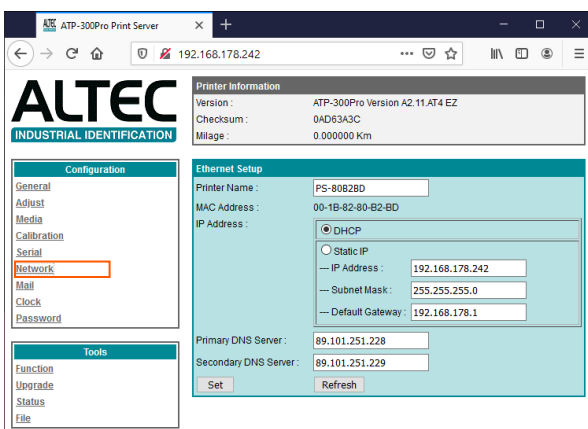

Printer Name

Host name of the printer

MAC Address

Static value (can't be changed)

IP Address

DHCP Dynamic (auto)

Static IP Set IP Address, Subnet Mask and

Default Gateway

DNS Server

Please do not change this setting.

Note:

Changes may have effect on the web interface.

Please Enter the (new) IP address again in your browser.

Mail

Notifications to e-mail

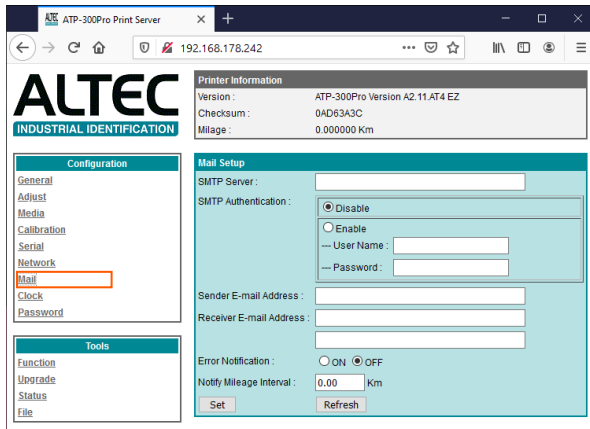

Set up e-mail notifications for errors.

Error notifications

Carriage open, Over heat, Paper jam, Paper empty, Ribbon error and Cutter error

Clock

Set up internal clock

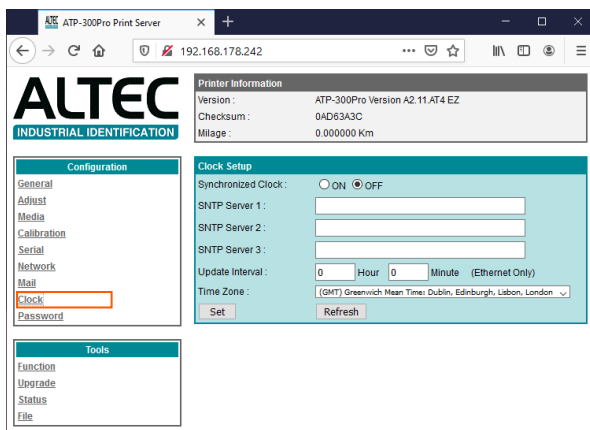

Synchronise the internal printer clock with time servers.

Specify SNTP Servers, update interval and time zone.

Password

Protect printer settings

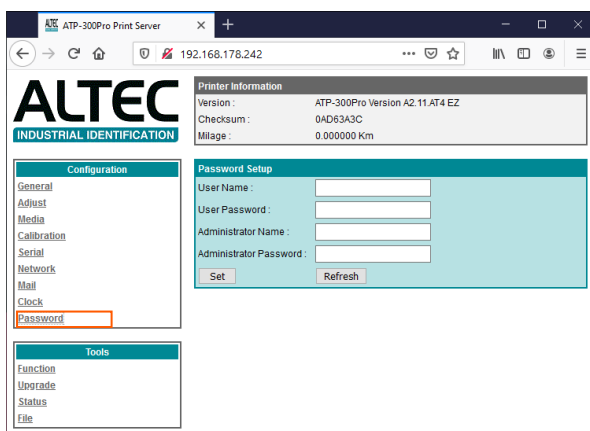

Create passwords for the **User** and **Administrator** account.

5.3 Tools

Function

These functions are performed directly on the printer.

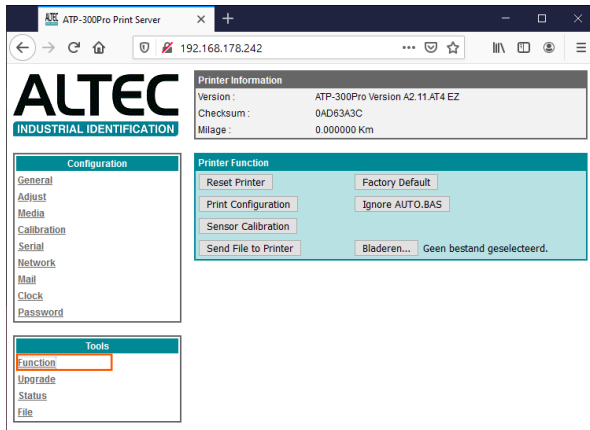

Reset Printer

Restart the printer. Use this function when an error occurs.

Factory Default

Reset all printer settings back to the default factory values.

Print Configuration

Print a test page with all current printer settings.

Please use media with a minimum width of 50mm (preferably 100mm).

Ignore AUTO.BAS

Restart the printer without a loaded (.bas) program.

Sensor Calibration

Calibrate the printer with current calibration settings.

Send File to Printer

Send a file to the printer memory (via 'Browse...').

Upgrade

Upgrade printer firmware

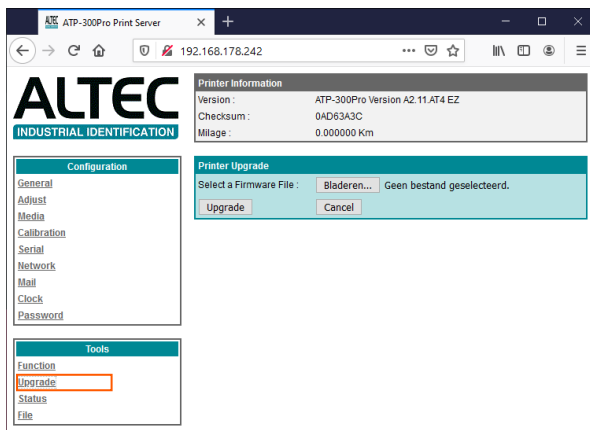

Upgrade the printer firmware

Use the 'Browse...' button to select a firmware file and click **Upgrade** to send it to the printer.

Important

Upgrade the printer firmware only upon request of Altec.

Status

Actual printer status

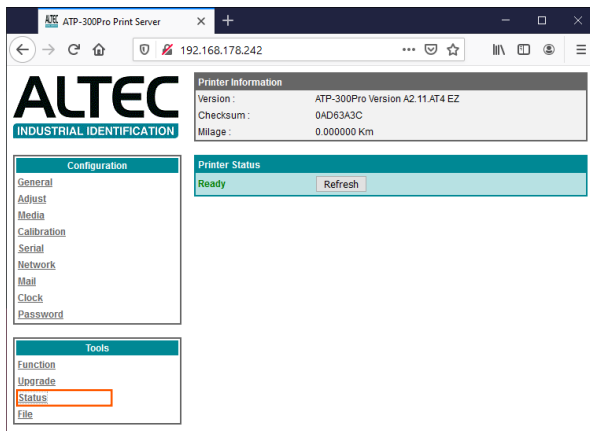

This shows the current status of the printer.

The **Refresh** button reloads the status.

Green notifications (ready)

Ready, Printing

Red notifications (errors)

Pause, Out of Memory, Carriage Open, Over Heat, Paper Jam, Paper Empty, Ribbon Error, Cutter Error

File

Manage files on your printer

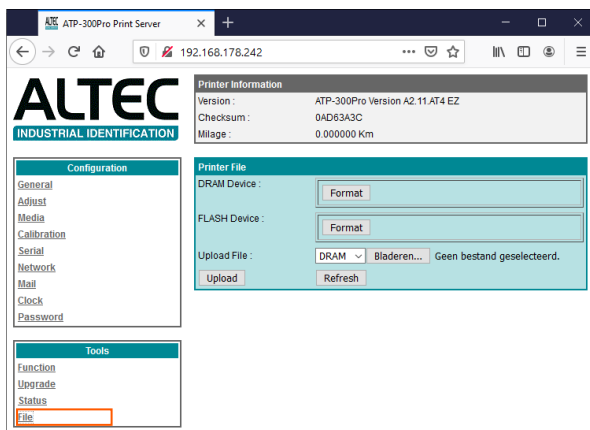

Format DRAM / FLASH Device

Delete all files on DRAM / FLASH device.

Upload File

Upload a file via 'Choose file...' and select DRAM or FLASH memory.

6 Printer management tool (TPM)



The **Printer management tool (TPM)** is a tool for Microsoft Windows to manage the ATP-300/600 Pro printer. With TPM you can:

- Check the printer status
- Configure printer settings
- Manage multiple printers

To download this tool on your PC, use the following link:

[Download Printer Management Tool \(TPM\)](#)

6.1 TPM overview

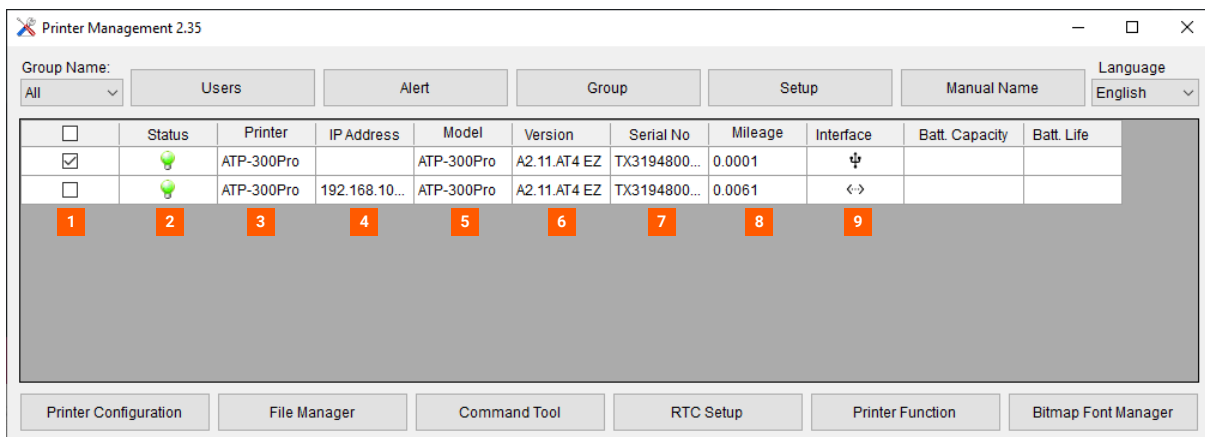

- | | | |
|--|---------------------|--------------------|
| 1. Select printer(s) | 5. Model | Printer model name |
| 2. Printer status | 6. Version | Firmware version |
| Printer is ready | 7. Serial No | Serial number |
| Error | 8. Mileage | Printed mileage |
| 3. Printer Printer name | 9. Interface | ⚡ USB / ↔ Ethernet |
| 4. IP Address When using Ethernet | | |

6.2 Printer settings

6.2.1 Printer configuration

Select the printer(s) in the list and click on **Printer Configuration**.

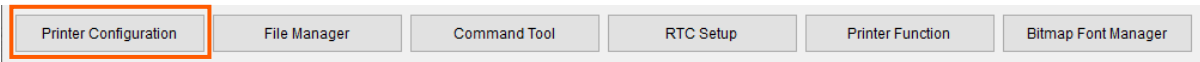

Basic

Apply basic settings to one or all printer(s).

Note: these settings might be overruled by label software.

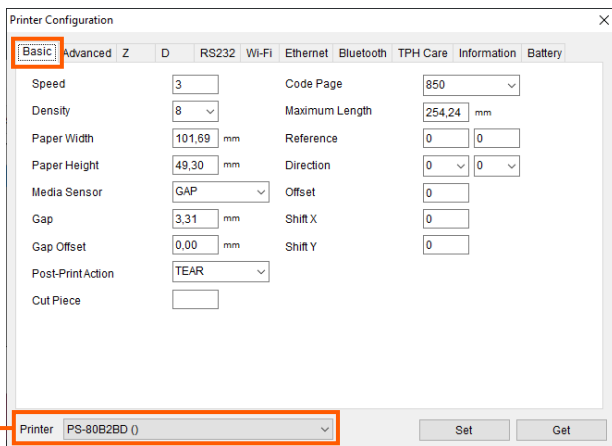

Speed

Density

Paper width

Paper height

Media Sensor

Gap

Gap Offset

Post-Print action

Cut Piece

Code Page

Maximum Length

Reference

Direction

Offset

Shift X / Y

Print speed (1 – 6 inch/s)

Printing temperature (0 - 15)

Media width in millimeters

Media height in millimeters

Gap / Black mark / Continuous

Gap size (height) in millimeters

Offset distance in millimeters

TEAR / PEAL / CUTTER / REWINDER / OFF

Cut after "X" labels

Keyboard country code

Maximum label detection length

Adjust print and tear-off position

Print direction (0 or 1)

Adjust tear-off position

Adjust print position

Printer selection

Select the printer(s) you want to apply the settings. This can be a specific printer or all printers.

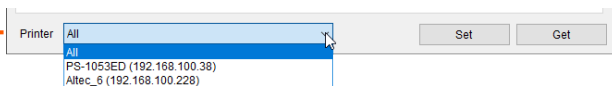

Advanced

Apply advanced settings to one or all printer(s).

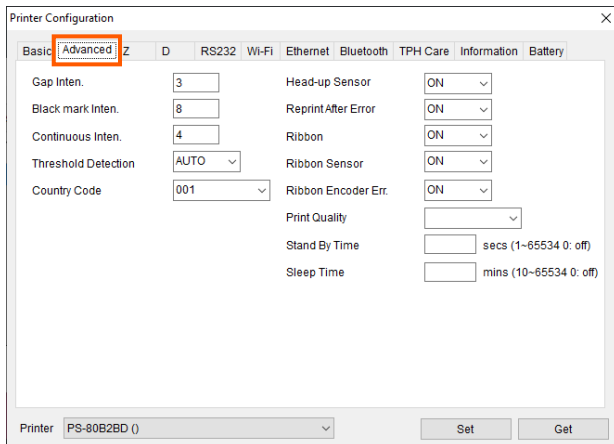

Gap Inten.

Black mark inten.

Continuous inten.

Threshold Detection

Country Code

Head-up Sensor

Reprint After Error

Ribbon

Ribbon Sensor

Ribbon Encode Err.

Print Quality

Stand By Time

Sleep Time

Gap sensor intensity

Black mark intensity

Continuous intensity

N/A for ATP-300/600 Pro

Keyboard country code

Top cover open/closed check

Reprint last label after error

Turn ribbon use on/off

Turn ribbon sensor on/off

Ink ribbon speed detection

N/A for ATP-300/600 Pro

N/A for ATP-300/600 Pro

N/A for ATP-300/600 Pro

Z / D configuration

Z: Use these settings when sending ZPL language to the printer.

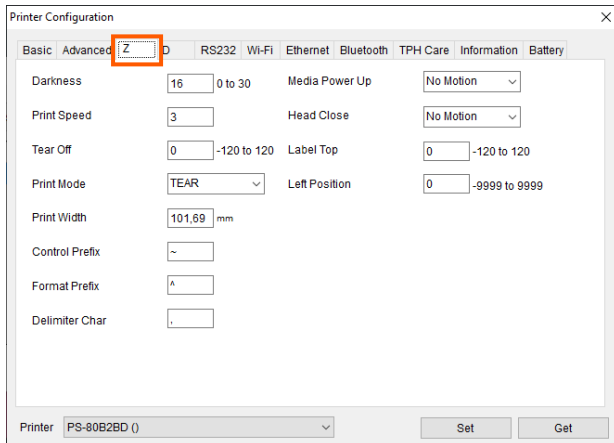

D: These functionalities are not available for ATP-300/600 Pro.

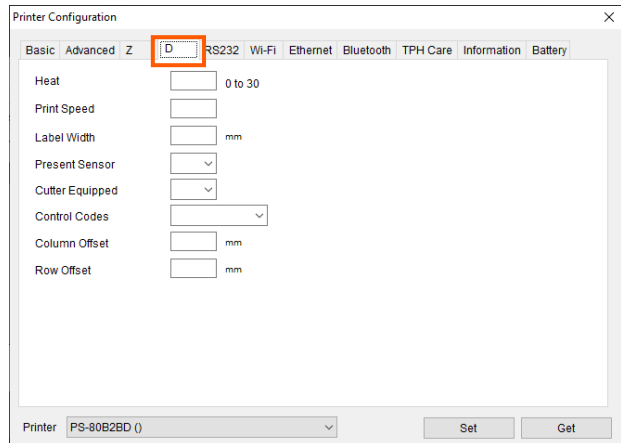

RS232 (serial port)

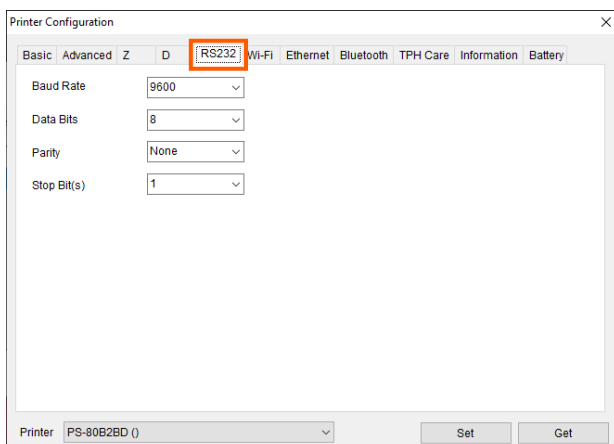

Port settings for the RS232 serial port

- Baud rate
- Data bits
- Parity
- Stop bit(s)

Wi-Fi

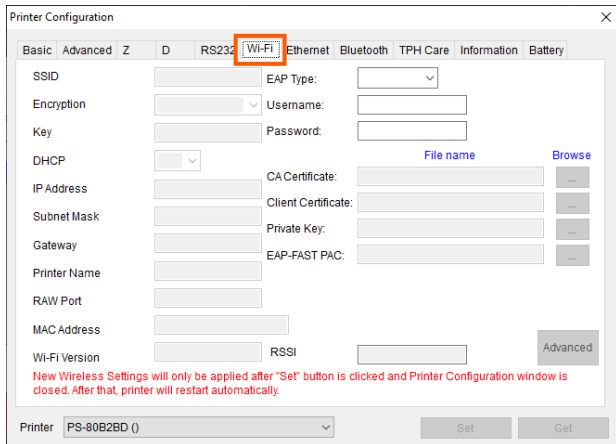

Settings for the (optional) Wi-Fi module

The optional Wi-Fi module can be requested from Altec.

Ethernet

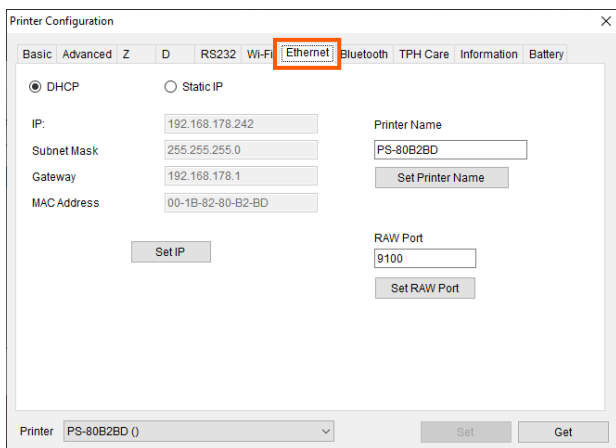

Settings for Ethernet connection

DHCP

Set printer name and RAW port

Static IP

Set (static) IP address, Subnet mask, Default gateway.
MAC address can not be changed.

Bluetooth

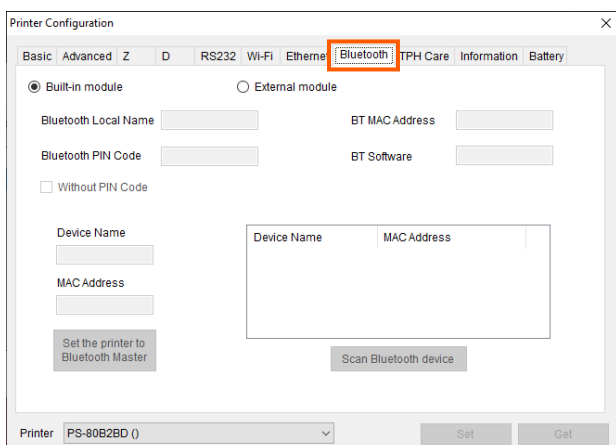

Settings for the (optional) Bluetooth module

The optional Bluetooth module can be requested from Altec.

TPH Care

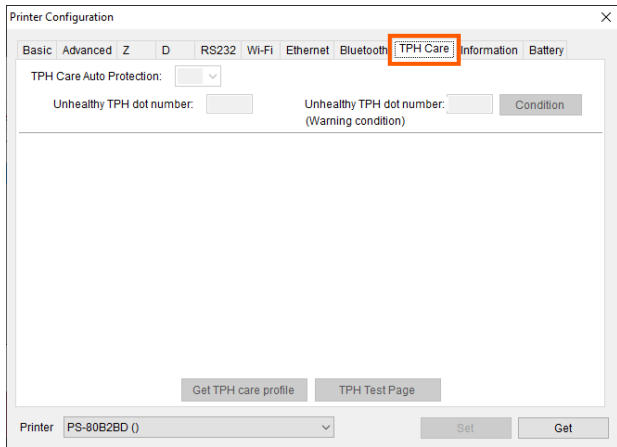

These settings are not available for the ATP-300/600 Pro.

Information

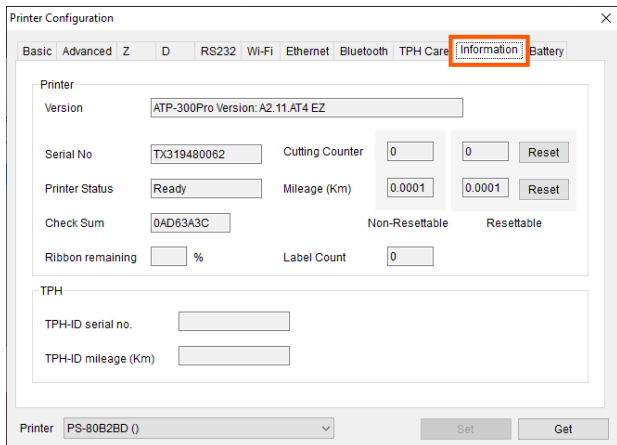

Overview of ATP-300/600 Pro printer information

Cutting counter / Mileage (km) can be reset here.

Battery

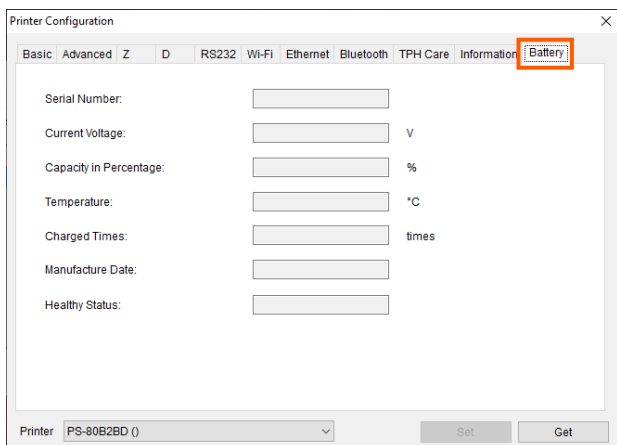

These settings are not available for the ATP-300/600 Pro.

6.2.2 File manager

Send files to the printer using **File manager**.

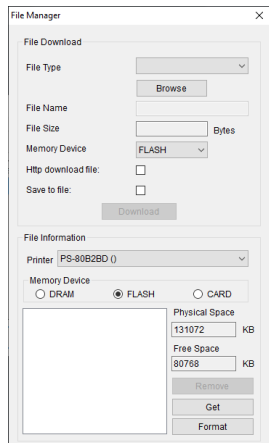
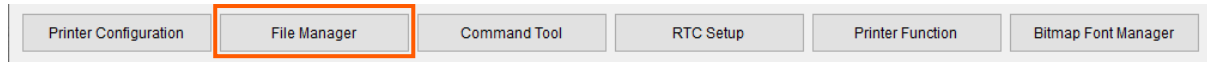

File Type	BMP (*.bmp), PCX (*.pcx), True Type Font, Bitmap fonts, Printer BASIC File (*.bas), Data File, Firmware File (*.new / *.rom), TCF File (*.tcf) and RAW Data
File name	Name of the loaded file
File size	Size of the loaded file in Bytes
Memory Device	DRAM, FLASH (default) or CARD
Download	Send file to the printer
File information	Get: retrieve a list of the files on DRAM / FLASH / CARD Then you can select files and remove (delete) them. Format: delete all the files in the specified memory

6.2.3 Command tool

Send commands using printer language to the printer with the **Command tool** function.

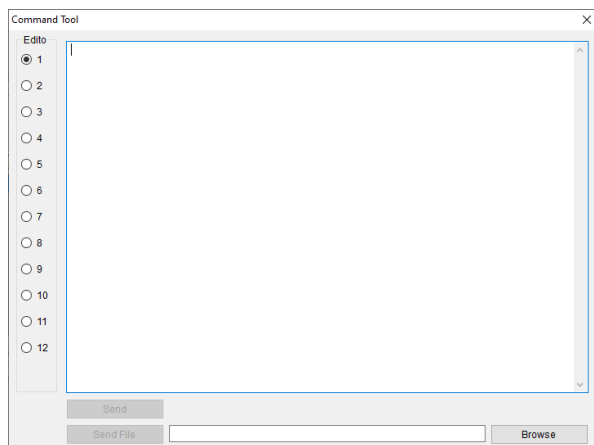

Put your command (printer language) in the white area.

Note Always close the command with an Enter (carriage return)

Send	Send the command to the printer
Send File	Load file and send it to the printer

6.2.4 RTC Setup

Send the system time to the printer.



RTC Setup ×

	Year	Month	Date	Hour	Minute	Second
System Time	2020	03	26	09	41	49
PS-80B2BD	<input type="text" value="2020"/>	<input type="text" value="03"/>	<input type="text" value="26"/>	<input type="text" value="09"/>	<input type="text" value="41"/>	<input type="text" value="50"/>

Click on **Set to System Time** to set the printer clock equal to the clock on your computer.

6.2.5 Printer function

These functions are performed directly on the printer.



Printer Function ×

-
-
-
-
-
-
-
-
-
-

1 | Calibrate

Calibrate ×

GAP Paper Height mm

Black Mark

Continuous Gap mm

Auto Selection

Choose the required sensor and enter the label height and gap.

Paper Height Vertical label height from gap to gap

Gap Height of the gap

2 | Reset Printer

Restart the printer. Use this function when an error occurs.

3 | Factory default

Reset all printer settings back to the default factory values.

4 | Print Test Page

Print a test page with all current media settings (dimensions).

5 | Configuration Page

Print a test page with all current printer settings.

6 | Ignore AUTO.BAS

Restart the printer without a loaded (.bas) program.

7 | Exit Line Mode / 8 | Exit Line Mode

To be used with ZPL.

9 | Wi-Fi Default

Reset Wi-Fi settings back to default.

10 | Dump Text

Sets the printer to dump mode. Reset the printer to leave dump mode.

6.2.6 Bitmap Font Manager

Load bitmap fonts into the printer.

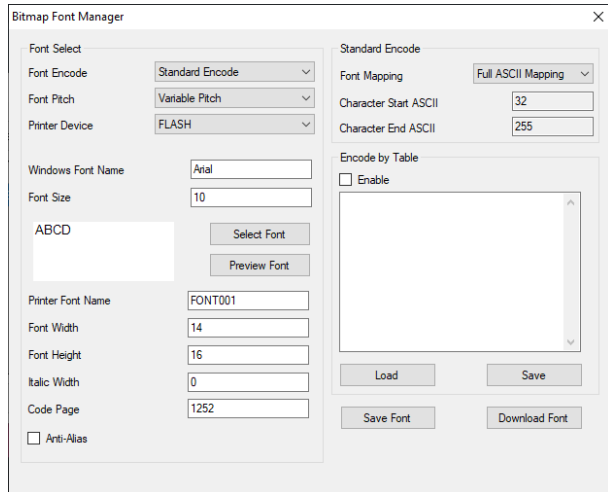
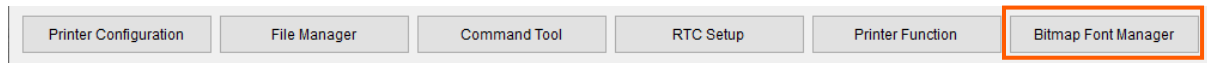

In **Bitmap Font Manager** you can load fonts into the printer.

This is sometimes used for **stand-alone** printing solutions

6.3 Program settings

6.3.1 Users

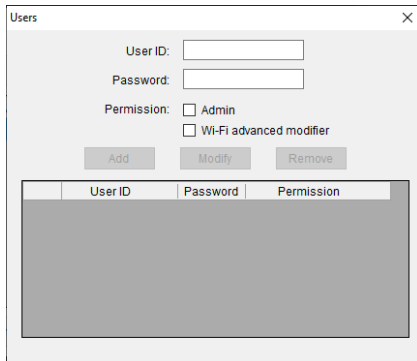
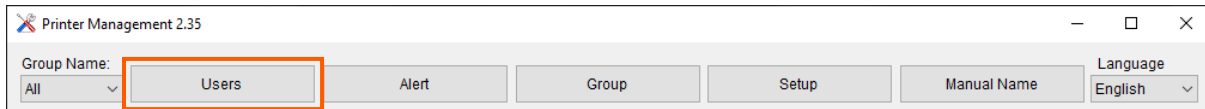

Create **users** within the Printer Management tool.

6.3.2 Alert

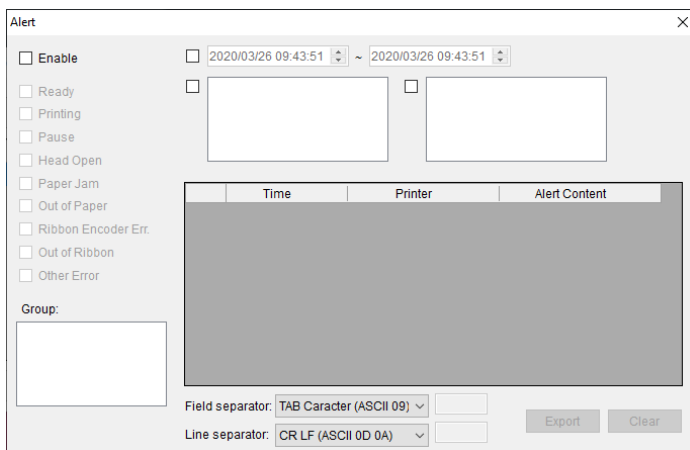
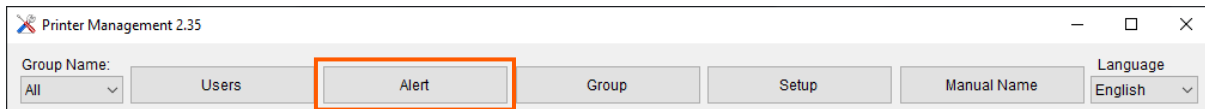

Send notifications (alerts) to users when the status of certain printer(s) - or printer groups - has changed.

6.3.3 Group

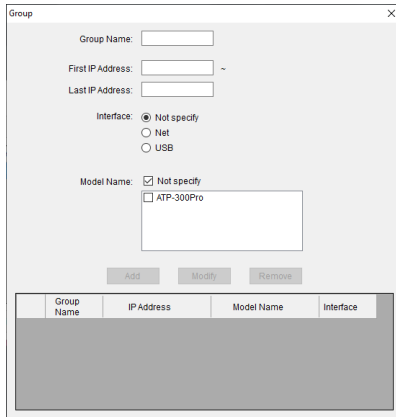
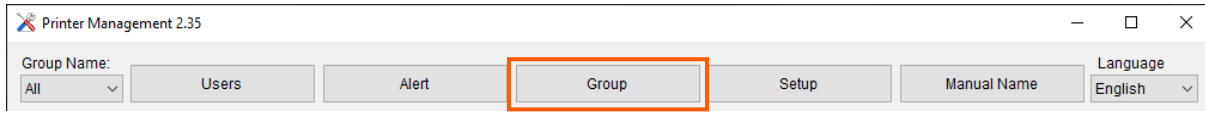

Set up printer group

Here you can set up groups of printers.

This way you can change settings in the Printer Management Tool and apply them directly to all printers in the group.

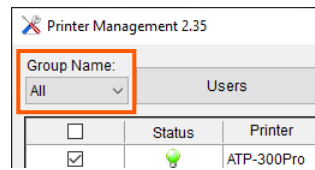

6.3.4 Setup

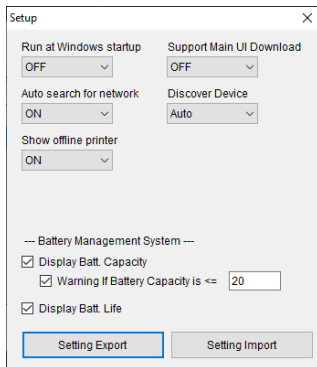
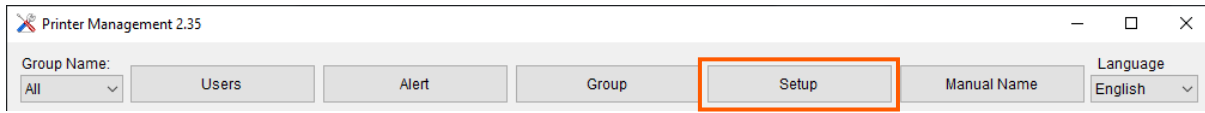

Change general program settings.

6.3.5 Manual name

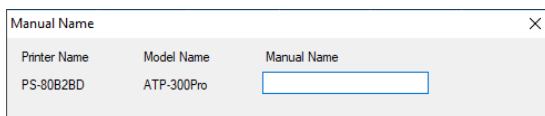
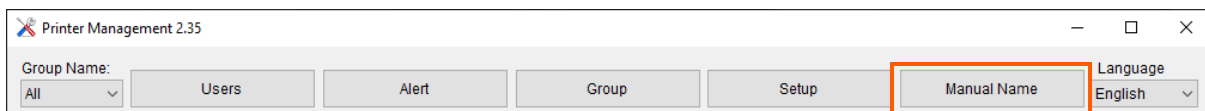

In **Manual Name** you can set a (alternative) printer name. This name will only be used in the Printer Management tool.

7 Cleaning

To keep your printer in optimal condition, it is recommended to clean the printer:

- when the platen roller is visibly soiled
- after each used roll of ink ribbon

7.1 Cleaning the printer



1. Open the top cover of the printer by pulling the **green levers** - located on each side of the printer - and lifting the top cover to the maximum open angle.



2. Get a **Cleaning Wipe** and remove it from the package.

Remove all visible dust and dirt inside the printer, paying attention to elements that come in contact with your media.

ALTEC CLEANING WIPES (25 PCS.)
Art.nr. 91001728



3. Remove the **waste roll** from the ribbon waste hub and place it on the ribbon supply cover.

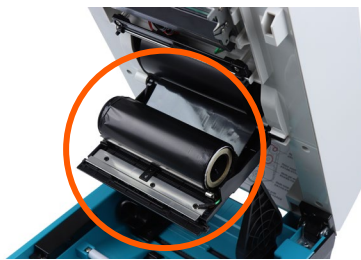



4. Clean the **print head** from left to right with the Cleaning Wipe.

Then place the **waste roll** back in the ribbon waste hub and close the ribbon supply cover.



5. Clean the **media guide bar** and turn it around to clean it completely around.



6. Clean the **platen roller** and turn it with both thumbs to clean it completely around.



Instruction video

Learn how to clean your printer with our instruction video.

[Watch video](#)

8 Support (FAQ)

Do you need any help setting up your printer or do you experience a problem during printing?
Please visit our [online FAQ](#). Here we collect instructions, common questions and solutions.

Note: Online F.A.Q. is currently only available in Dutch



F.A.Q.
Instructions and troubleshooting

[Go to FAQ](#)

Need assistance from a representative?

Do you need support or assistance from one of our representatives?
Please call or e-mail us:

The Netherlands

 T. +31(0)78 - 615 20 33

 info@altec.nl

Belgium

 T. +32(0)2 - 270 34 88

 info@altec.be



ATP 300
PRO

ATP 600
PRO